

## WFP GLOSSARY

<b>AFE</b>	<i>Authorization for Expenditure</i>	A budgetary document for estimating expenses that is provided to partners for approval prior to commencement of construction or design.
<b>CEP</b>	<i>Construction Execution Plan</i>	A guidance document that outlines how the project will be undertaken. The CEP typically includes: Contract Strategy, Project Controls, Project Wide Integration Plan, Change Management, Risk Management, Reporting, Human Resource Plan, Communication Plan, Environmental, Health & Safety Plan, QA/QC Plan, On Site and Offsite Items, Equipment, and Materials.
<b>CWA</b>	<i>Construction Work Area</i>	A portion (square) of the plot plan that has been defined by construction as being a logical area of work. The CWA includes all of the disciplines.
<b>CWP</b>	<i>Construction Work Package</i>	An executable construction deliverable that defines in detail a specific scope of work and should include a budget and schedule that can be compared with actual performance. The scope of work is such that it does not overlap another CWP. The CWP can be used as a scoping document for Requests for Proposal and Contracts.
<b>DBM</b>	<i>Design Basis Memorandum</i>	A "Controlled Document" produced during the front-end engineering study phase that defines the basic design parameters for the intended project. Generation, review, and approval of the DBM are prerequisites to AFE approval and release for development of the Engineering Design Specification (EDS).
<b>DEP</b>	<i>Detailed Engineering Phase</i>	The phase of engineering following EDS, after approval has been given for the project. The DEP provides the specifications and construction drawings that detail all engineering aspects for the construction of a project.
<b>EDS</b>	<i>Engineering Design Specification</i>	The product of front-end engineering development (basic engineering) that defines all elements of project scope and is the Control Document for commencement of detail engineering and procurement activities on the project. A companion document to the EDS is the Project Execution Plan that sets forth the program for project implementation.
<b>EPC</b>	<i>Engineering Procurement Construction</i>	An acronym for Engineering, Procurement, and Construction. EPC describes an organization type that manages the engineering, procurement, and construction aspects of a project
<b>EWP</b>	<i>Engineering Work Package</i>	An engineering deliverable that is used to develop CWPs and that defines a scope of work to support construction in the form of drawings, procurement deliverables, specifications, and vendor support. The EWP is released in an approved sequence that is consistent with the CWP schedule. The scope of work is typically both by discipline and by area.
<b>IWP</b>	<i>Installation Work Package</i>	A detailed execution plan that ensures all elements necessary to complete the scope of the IWP are organized and delivered before work is started. This detailed planning enables craft persons to perform quality work in a safe, effective, and efficient manner. Generally, the scope of

		work associated with the IWP is small enough that it could be completed by a single-foreman team, typically in a one- or two-week time frame.
<b>IFC</b>	<i>Issued for Construction</i>	Status given to drawings that have been provided for information purposes only and that cannot be used for construction purposes.
<b>IFI</b>	<i>Issued for Information</i>	Status given to drawings that have been provided for information purposes only and that cannot be used for construction purposes.
<b>IFL</b>	<i>Indirect Field Labor</i>	Labour that supervises or supports the direct field labour but that is not responsible for constructing the final project.
<b>IFR</b>	<i>Issued for Review</i>	Status given to drawings that have been issued for review and that have not been approved to be used for construction purposes.
<b>RFI</b>	<i>Request for Information</i>	A standard business process whose purpose is to collect written clarification that will enable the initiator to determine how to proceed.
<b>RFR</b>	<i>Ready for Release</i>	Status given to an FIWP that is complete. All required materials, equipment, tools, labour, and predecessor work must be confirmed prior to release of the package.
<b>VPM</b>	<i>Virtual Plant Model</i>	A three-dimensional virtual environment that replicates the design and layout of the actual facility.
<b>WBI</b>	<i>Work Breakdown Index</i>	A hierarchical summary of a specific Work Breakdown Structure.
<b>WBS</b>	<i>Work Breakdown Structure</i>	A project management tool used for defining and organizing the total scope of a project. The WBS is used to develop a hierarchical tree structure.
<b>WFP</b>	<i>WorkFace Planning</i>	The process of organizing and delivering all the elements necessary, before work is started, to enable craft persons to perform quality work in a safe, effective, and efficient manner.
<b>Type 1 Estimate</b>	Preliminary estimate based on planned throughput, schedule, and process approach. The Type 1 estimate is often a top down estimate based on similar projects.	
<b>Type 2 Estimate</b>	At this stage, the design has been fully optimized and a basis of design has been finalized (15% to 30% engineering completed) so the estimate will be prepared on a “bottom up” basis. This estimate becomes the Master Control Estimate used for the remainder of the project.	
<b>Type 3 Estimate</b>	Typically, the contracting strategy has been developed and engineering work has been performed (2% to 10%). Typically, budget quotes have been received on all long lead equipment. Bulks should be based either on cost estimating software (like Kbase modeling) or factored off equipment pricing.	
<b>Type 4 Estimate</b>	Typically, engineering work (1% to 5%) has been performed to help define the project. At this stage, a major equipment list has been prepared with rough sizing. Equipment pricing is typically based on historical data or budgetary quotes and installation/bulk costs are factored off equipment pricing.	
<b>Type 5 Estimate</b>	Project early estimates are usually based on very broad objectives and limited technical information. Estimates are prepared on the basis of key assumptions with very little upfront project definition or engineering effort.	

<b>Level 1 Schedule</b>	Project Master Schedule (PMS). A major milestone type schedule that highlights major project activities and milestones, with reference to key deliverables throughout the Project.
<b>Level 2 Schedule</b>	Summary Master Schedule (SMS). Generated as a summary of the Level 3 Project Coordination Schedule(s). Depicts the overall schedule broken down into EPC components by area.
<b>Level 3 Schedule</b>	Project Coordination Schedule (PCS). Consists of a set of EPC integrated schedules based on Critical Path Methodology (CPM) and developed by Engineering with Construction input regarding key milestones and applicable deliverables across the design areas.
<b>Level 4 Schedule</b>	Project Control Level Schedule. Represents an expansion of the level 3 schedules and will be established within the integrated project schedule. The established WBS will be used as a basis for the development of the schedule's structure and will be used to manage construction activities throughout the Project to completion.
<b>Level 5 Schedule</b>	Represents a further breakdown of the activities of a Level 4 Schedule, including the detailed tasks within an FIWP.



## Pipe Work Pack -Work Steps Report



ConstructSim

### Work Package: 6B53A1E1P502

ISO	Sheet	Rev	Task Title	Bore	Material	Area	Sys	Qty	UOM	Hrs	Pct
<input type="checkbox"/> WT6-AP-126-DAC1-APD-AC		0	Rule 1 - Bolt-up - BOLTUP-01 6BAC126PA (WT6-AP-126-DAC1-APD-AC)	2	Galv CS			1	EA	0	0
<input type="checkbox"/> WT6-AP-126-DAC1-APD-AC		0	Rule 1 - Linetm - INSTRUMENT W6-PG-9652 (WT6-AP-126-DAC1-APD-AC)	0.5	Galv CS			1	EA	0	0
<input type="checkbox"/> WT6-AP-126-DAC1-APD-AC		0	Rule 1 - Hang Spool - SPOOL 6BAC126AC	2	Galv CS			6.632	LF	2.1056	0
<input type="checkbox"/> WT6-AP-126-DAC1-APD-AC		0	Rule 2 - Fit-Up Spool - SPOOL 6BAC126AC	2	Galv CS			6.632	LF	8.4223	0
<input type="checkbox"/> WT6-AP-126-DAC1-APD-AC		0	Rule 3 - Install Spool - SPOOL 6BAC126AC	2	Galv CS			6.632	LF	10.528	0
<input type="checkbox"/> WT6-AP-126-DAC1-APD-AC		0	Rule 1 - Support - SUPPORT SU-01 WT6-PDA-PS-5291 (WT6-AP-126-DAC1-APD-AC)	2	Galv CS			1	EA	0	0
<input type="checkbox"/> WT6-AP-126-DAC1-APD-AC		0	Rule 1 - Support - SUPPORT SU-02 PD-DP-013 (WT6-AP-126-DAC1-APD-AC)	2	Galv CS			1	EA	0	0
<input type="checkbox"/> WT6-AP-126-DAC1-APD-AC		0	Rule 1 - Linetm - VALVE V-01 VALVE RECAP NO: 6BAC126VA (WT6-AP-126-DAC1-APD-AC)	0.75	Galv CS			1	EA	0	0
<input type="checkbox"/> WT6-AP-126-DAC1-BPD-AD		0	Rule 1 - Hang Spool - SPOOL 6BAB126AD	2	Galv CS			31.99	LF	4.4091	0
<input type="checkbox"/> WT6-AP-126-DAC1-BPD-AD		0	Rule 2 - Fit-Up Spool - SPOOL 6BAB126AD	2	Galv CS			31.99	LF	17.636	0
<input type="checkbox"/> WT6-AP-126-DAC1-BPD-AD		0	Rule 3 - Install Spool - SPOOL 6BAB126AD	2	Galv CS			31.99	LF	22.045	0

Wednesday, April 23, 2008

Work Steps Report - Work Package: 6B53A1E1P502

Page 1 of 19

Work Steps Report (Sample)

## WORKFACE PLANNING FOR CM CONTRACTS

### WorkFace Planning

Owner requires that Construction Management (CM) Contractor verify and servile the implementation of WorkFace Planning by the Construction Contractor, in accordance with the Construction Owners Association of Alberta (COAA) model as published on the COAA website ([www.coaa.ab.ca](http://www.coaa.ab.ca).) The CM shall review and comment on Construction Contractor's submitted WorkFace Execution Plan taking into account the minimum standards of the COAA model contents and monitor Construction Contractor's implementation being in accordance with terms and conditions agreed between Owner and Construction Contractor.

The Construction Contractor's WorkFace Planning Execution Plan, complete with a WorkFace Planning Score Card, shall be prepared by the Construction Contractor and submitted to CM Contractor for review and the Owner for review and approval no later than 90 days in advance of the beginning of permanent plant installations at the Site or as otherwise agreed. The CM Contractor shall submit comments to the Owner for review and with the Owners comments may be submitted to the Construction Contractor for inclusion to the WorkFace Execution Plan prior to approval.

CM Contractor shall, as part of its work scope as required by Owner, conduct periodic audits and ongoing surveillance of the Construction Contractor - WorkFace Planning efforts including its lower tier subcontractors using the WorkFace Planning Score Card at the frequency and times noted therein. Owner shall monitor and reserves the right at any time deemed necessary to review audit results performed by CM group using the WorkFace Planning Score Card on the execution of the Construction Contractor's WorkFace Execution Plan throughout the duration of the contract to determine if WorkFace Planning is being implemented in accordance with the agreed upon WorkFace Execution Plan. In cases where significant deviations to the WorkFace Execution Plan are identified either by the Owner or the CM Contractor, the Construction Contractor shall immediately prepare an action plan for correction of the deficiencies and shall immediately implement this plan upon approval of the owner.

The Construction Contractor will divide a Work Design Area into a series of preferred Construction Work Packages (each a "CWP"). These CWP definitions will be issued to the

Owner, CM Contractor and Engineering Contractor in order to align relevant portions of the overall scope of Work with the Engineering deliverables e.g.: Engineering Work Packages (EWP's), Materials and Equipment. With Owner and CM Contractor participation, Construction Contractor and Engineering Contractor shall discuss and form agreement for mutual benefit with regard to this packaging boundaries. This cooperation shall continue throughout the project to completion.

If EP Contractor and Construction Contractor cannot agree on the EWP/CWP breakdown the Owner together with the EP Contractor and Construction Contractor will formulize an agreement that is beneficial to the overall project.

During the EDS or preliminary engineering stage of the project, as a result of agreement between the Engineering Contractor and the Construction Contractor, the Construction Contractor will identify the CWP's and develop a CWP Release Plan: that will specify the number, approximate manhour size, and release date of each CWP. The CWP Release Plan will include standard templates to be used, the number of packages, and planned craft loading to accomplish the tasks in the CWP's. Construction Contractor shall submit the CWP Release Plan to the CM Contractor for review and Owner for review and approval. If Owner or CM Contractor has comments on the initial submittal and if requested by Owner, the Construction Contractor will resubmit the CWP Release Plan which will include Owner's and/or CM Contractor's comments in order to gain Owner's approval. The date of the Construction Contractor's initial submittal of the CWP Release Plan is to be agreed upon between Owner, CM group and Construction Contractor at the beginning of the EDS or preliminary engineering phase.

Each CWP will include but not limited to the following:

- A detailed description of the Scope of Work for a defined area that has been released for execution by the Construction Contractor
- A detailed Bill of Materials (BOM) specifying all quantities making up the scope of Work released by the CWP.
- A schedule detailing commencement and completion dates for scope of Work released by the CWP.
- Technical requirements, references and information pertinent to the scope of Work released in the CWP.
- Safety considerations with respect to the Work/Risk Assessment.

As Issued-for-Construction (IFC) CWP's are released, the Construction Contractor and/or its lower tier subcontractors shall provide the following:

- Roles and responsibilities for Construction Contractor and Sub-Contractors
- Safety considerations with respect to the Work/Risk Assessment.
- Dedicated, suitably trained WorkFace Planners who have either completed the COAA Fundamentals Course or equivalent Owner-developed course to break the CWP into a series of specific WorkFace Planning work packages called Installation Work Packages (IWP's). These dedicated WorkFace Planners will be accountable to complete and signoff as ready the IWP's before the IWP is released to the crew.
- Dedicated Integration Planner with assigned responsibility to coordinate and lead the efforts of the WorkFace Planners and resolve anticipated conflicts proactively between the different IWP's.
- Dedicated Resource Coordinators with assigned responsibility for areas such as material identification and control, scaffolding, construction equipment, specialty tools, and other resources needed to support the WorkFace Planning effort.
- Experienced personnel including craft supervision to review the scope and completeness of IWP's.
- Work force and leadership to execute IWP's.
- Personnel and systems to report progress and performance of IWP's in an agreed upon format and frequency with the Owner.
- Prepare and maintain detailed schedules and spreadsheets tracking, monitoring, and closing-out IWP's from start to completion of each IWP during the construction phase of the project.
- Provide quality assurance personnel to audit compliance to IWP instructions and requirements

Prior to the CWP's reaching IFC stage, the Construction Contractor and/or its lower tier subcontractors shall develop a preliminary IWP Release Plan for each CWP indicating the approximate size and planned release date for each IWP. The Owner and CM Contractor will review the Contractor's IWP Release Plan and Owner shall approve. If Owner or CM Contractor has comments on the initial submittal and if requested by Owner, the Construction Contractor will resubmit the IWP Release Plan which will include Owner's and/or CM Contractor comments in order to gain Owner's approval. The date of the Contractor's initial submittal of the IWP Release Plan is to be agreed upon between Owner, CM Contractor and Construction Contractor during the EDS or preliminary engineering phase of the project.

The Construction Management Contractor shall be responsible for the following:

- Review and comments on the Construction Contractor's - CWP Release Plan, CWP – EWP alignment and other appropriate items, these comments shall be submitted to the Owner for review and may be included with the Owners comments and submitted to the Construction Contractor for inclusion to the Plan prior to approval by Owner
- Review the detailed description of the CWP Scope of Work for a defined area and submit comments to Owner for review and may be include with the Owner's comments and submitted to the Construction Contractor for inclusion in the Plan prior to the release for execution by the Construction Contractor
- Monitor, audit and perform ongoing surveillance on the Construction Contractor's - Construction Work Package Release Plan and its execution as requested by Owner
- Review and comments on the Construction Contractor's – Installation Work Package Release Plan, these comments shall be submitted to the Owner for review and may be included with Owners comments and submitted for inclusion to the Plan prior to approval by Owner
- Monitor, audit and perform ongoing surveillance on the Construction Contractor's – Installation Work Package Release Plan and its execution as requested by Owner
- Issue copies of audit schedule's and audit findings to the Owner



## WORKFACE PLANNING FOR EP CONTRACTS

### WorkFace Planning

Owner requires that Engineering and Procurement (EP) Contractor work with and support the Construction Contractor with its requirement to implement WorkFace Planning, in accordance with the Construction Owners Association of Alberta (COAA) model as published on the COAA website ([www.coaa.ab.ca](http://www.coaa.ab.ca).) The EP Contractor shall be aware that the Construction Contractor will submit a WorkFace Planning Execution Plan that will take into account the minimum standards of the COAA model contents and shall implement in accordance with terms and conditions agreed between Owner and Construction Contractor.

The Construction Contractor will divide a Work Design Area into a series of preferred Construction Work Packages (each a "CWP"). These CWP's will be issued to the Owner and EP Contractor in order to align relevant portions of the overall scope of Work with the EP Contractor deliverables e.g.: Engineering Work Packages (EWP's), Materials and Equipment. With Owner participation, Construction Contractor and EP Contractor shall discuss and form agreement for mutual benefit with regard to these packaging boundaries. This cooperation shall continue throughout the project to completion.

If EP Contractor and Construction Contractor cannot agree on the EWP/CWP breakdown the Owner together with the EP Contractor and Construction Contractor will formulate an agreement that is beneficial to the overall project.

During the EDS or preliminary engineering stage of the project, as a result of agreement between the EP Contractor and the Construction Contractor, the Construction Contractor will identify the CWP's and develop a CWP Release Plan.

Each CWP will include but not limited to the following:

- A detailed description of the Scope of Work for a defined area that has been released for execution by the Construction Contractor
- A detailed Bill of Materials (BOM) specifying all quantities making up the scope of Work released by the CWP.

- A schedule detailing commencement and completion dates for scope of Work released by the CWP.
- Technical requirements, references and information pertinent to the scope of Work released in the CWP.
- Safety considerations with respect to the Work/Risk Assessment.

The Engineering Contractor should be aware that the Construction Contractor is required to prepare and maintain detailed schedules and spreadsheets tracking, monitoring, and closing-out IWP's from start to completion of each IWP during the construction phase of the project. Engineering Contractor shall be required to support this IWP Release Plan and its processes by maintaining engineering deliverable schedule requirements (EWP's) which include Materials and Equipment.

Prior to the CWP's reaching IFC stage, the Construction Contractor and/or its lower tier subcontractors shall develop a preliminary IWP Release Plan for each CWP indicating the approximate size and planned release date for each IWP. The Owner will review the Contractor's IWP Release Plan and Owner shall approve. If Owner has comments on the initial submittal and if requested by Owner, the Construction Contractor will resubmit the IWP Release Plan taking into account Owner's comments in order to gain Owner's approval. The date of the Contractor's initial submittal of the IWP Release Plan is to be agreed upon between Owner, CM group and Construction Contractor during the EDS or preliminary engineering phase of the project.

The Engineering and Procurement Contractor shall be responsible for the following:

- Review and comment on the Construction Contractor's - CWP Release Plan, the CWP – EWP alignment, and other appropriate items, these comments shall be submitted to the Owner for review, Owner and EP Contractor comments may be submitted to the Construction Contractor for inclusion to the Plan prior to approval by Owner
- Review the detailed description of the CWP Scope of Work for a defined area and submit comments to Owner and Construction Contractor prior to the release for execution by the Construction Contractor
- Mutually agree with the Construction Contractor with regard to the Construction Work Package Plan and design area breakdown into CWP's and corresponding EWPs
- Support CWP required dates with EWP, Material and Equipment deliverable issue date

## WORKFACE PLANNING FOR EPC CONTRACTS

### WorkFace Planning

Owner requires that Contractor implement WorkFace Planning, in accordance with the Construction Owners Association of Alberta (COAA) model as published on the COAA website ([www.coaa.ab.ca](http://www.coaa.ab.ca).) The Contractor shall submit their WorkFace Execution Plan taking into account the minimum standards of the COAA model contents and Contractor's implementation shall be in accordance with terms and conditions agreed between Owner and Contractor.

The Contractor's WorkFace Planning Execution Plan, complete with a WorkFace Planning Score Card, shall be prepared by the Contractor and submitted to Owner for review and approval no later than 90 days in advance of the beginning of permanent plan installations at the Site or as otherwise agreed.

Contractor shall, or if requested by Owner, conduct periodic audits of its WorkFace Planning efforts including its lower tier subcontractors using the WorkFace Planning Score Card at the frequency and times noted therein. Owner shall monitor and reserves the right at any time deemed necessary to audit using their WorkFace Planning Score Card on the execution of the Contractor's WorkFace Execution Plan throughout the duration of the contract to determine if WorkFace Planning is being implemented in accordance with the agreed upon WorkFace Execution Plan. In cases where significant deviations to the WorkFace Execution Plan are identified either by the Owner or the Contractor, the Contractor shall immediately prepare an action plan for correction of the deficiencies and shall immediately implement this plan upon approval of the owner.

The Contractor will divide a Work Design Area into a series of Construction Work Packages (each a "CWP"). CWP's will be issued by the Contractor's engineering group in order to transfer relevant portions of the overall scope of Work to the Contractor's Construction group.

During the EDS or preliminary engineering stage of the project, as a result of agreement between the Contractor's Engineering group and the Contractor's Construction group, the Contractor will identify the CWP's and develop a CWP Release Plan that will specify the number, approximate manhour size, and release date of each CWP. The CWP Release Plan will

include standard templates to be used, the number of packages, and planned craft loading to accomplish the tasks in the CWP's. Contractor shall submit the CWP Release Plan to the Owner for review and approval. If Owner has comments on the initial submittal and if requested by Owner, the Contractor will resubmit the CWP Release Plan taking into account Owner's comments in order to gain Owner's approval. The date of the Contractor's initial submittal of the CWP Release Plan is to be agreed upon between Owner and Contractor at the beginning of the EDS or preliminary engineering phase.

Each CWP will include but not limited to the following:

- A detailed description of the Scope of Work for a defined area that has been released for execution to the Contractor's Construction group
- A detailed Bill of Materials (BOM) specifying all quantities making up the scope of Work released by the CWP.
- A schedule detailing commencement and completion dates for scope of Work released by the CWP.
- Technical requirements, references and information pertinent to the scope of Work released in the CWP.
- Safety considerations with respect to the Work/Risk Assessment.

As Issued-for-Construction (IFC) CWP's are released, the Contractor and/or its lower tier subcontractors shall provide the following:

- Roles and responsibilities of Owner and Contractors
- Safety considerations with respect to the Work/Risk Assessment.
- Dedicated, suitably trained WorkFace Planners who have either completed the COAA Fundamentals Course or equivalent Owner-developed course to break the CWP into a series of specific WorkFace Planning work packages called Installation Work Packages (IWP's). These dedicated WorkFace Planners will be accountable to complete and signoff as ready the IWP's before the IWP is released to the crew.
- Dedicated Integration Planner with assigned responsibility to coordinate and lead the efforts of the WorkFace Planners and resolve anticipated conflicts proactively between the different IWP's.
- Dedicated Resource Coordinators with assigned responsibility for areas such as material identification and control, scaffolding, construction equipment, specialty tools, and other resources needed to support the WorkFace Planning effort.
- Experienced personnel including craft supervision to review the scope and completeness of IWPs.

- Work force and leadership to execute IWP's.
- Personnel and systems to report progress and performance of IWP's in an agreed upon format and frequency with the Owner.
- Prepare and maintain detailed schedules and spreadsheets tracking, monitoring, and closing-out IWP's from start to completion of each IWP during the construction phase of the project.
- Provide quality assurance personnel to audit compliance to IWP instructions and requirements

Prior to the CWP's reaching IFC stage, the Contractor and/or its lower tier subcontractors shall develop a preliminary IWP Release Plan for each CWP indicating the approximate size and planned release date for each IWP. The Owner will review the Contractor's IWP Release Plan and approve. If Owner has comments on the initial submittal and if requested by Owner, the Contractor will resubmit the IWP Release Plan taking into account Owner's comments in order to gain Owner's approval. The date of the Contractor's initial submittal of the IWP Release Plan is to be agreed upon between Owner and Contractor during the EDS or preliminary engineering phase of the project.

## WORKFACE PLANNING FOR EPCM CONTRACTS

### WorkFace Planning

Owner requires that Engineering, Procurement and Construction Management (EPCM) Contractor work with and support the Construction Contractor with its requirement to implement WorkFace Planning, in accordance with the Construction Owners Association of Alberta (COAA) model as published on the COAA website ([www.coaa.ab.ca](http://www.coaa.ab.ca).) The EPCM Contractor shall review and comment on the Construction Contractor submitted WorkFace Execution Plan taking into account the minimum standards of the COAA model contents and shall monitor Construction Contractor's implementation in being in accordance with terms and conditions agreed between Owner and Construction Contractor.

The Construction Contractor's WorkFace Planning Execution Plan, complete with a WorkFace Planning Score Card, shall be prepared by the Construction Contractor and submitted to the EPCM Contractor for review and Owner for review and approval no later than 90 days in advance of the beginning of permanent plant installations at the Site or as otherwise agreed. The EPCM Contractor comments shall be submitted to the Owner for review and may be incorporated with the Owners comments and submitted to the Construction Contractor for inclusion to the Plan prior to approval by Owner

The EPCM Contractor shall, as part of work scope as require by Owner, conduct periodic audits and ongoing surveillance of the Construction Contractors WorkFace Planning efforts including its lower tier subcontractors using the WorkFace Planning Score Card at the frequency and times noted therein. Owner shall monitor and reserves the right at any time deemed necessary to audit the Construction Contractor using the WorkFace Planning Score Card on the execution of the Construction Contractor's WorkFace Execution Plan throughout the duration of the contract to determine if WorkFace Planning is being implemented in accordance with the agreed upon WorkFace Planning Execution Plan. In cases where significant deviations to the WorkFace Planning Execution Plan are identified either by the Owner or the EPCM Contractor: the Construction Contractor shall immediately prepare an action plan for correction of the deficiencies and shall immediately implement this plan upon approval of the owner.

The Construction Contractor will divide a Work Design Area into a series of preferred Construction Work Packages (each a "CWP"). These CWP's will be issued to the Owner and

EPCM Contractor in order to align relevant portions of the overall Scope of Work with the EPCM Contractor deliverables e.g.: Engineering Work Packages (EWP's), Materials and Equipment. With Owner participation, Construction Contractor and EPCM Contractor shall discuss and form agreement for mutual benefit with regard to these packaging boundaries. This cooperation shall continue throughout the project to completion.

If EPCM Contractor and Construction Contractor cannot agree on the EWP/CWP breakdown the Owner together with the EPCM Contractor and Construction Contractor will formulate an agreement that is beneficial to the overall project.

During the EDS or preliminary engineering stage of the project, as a result of agreement between the EPCM Contractor and the Construction Contractor, the Construction Contractor will identify the CWP's and develop a CWP Release Plan that will specify the number, approximate manhour size, and release date of each CWP. The CWP Release Plan will include standard templates to be used, the number of packages, and planned craft loading to accomplish the tasks in the CWP's. Construction Contractor shall submit the CWP Release Plan to the EPCM Contractor for review and Owner for review and approval. If Owner or EPCM Contractor has comments on the initial submittal and if requested by Owner, the Construction Contractor will resubmit the CWP Release Plan which will include Owner's and/or EPCM Contractor's comments in order to gain Owner's approval. The date of the Construction Contractor's initial submittal of the CWP Release Plan is to be agreed upon between Owner and Construction Contractor at the beginning of the EDS or preliminary engineering phase.

- Each CWP will include but not limited to the following:
- A detailed description of the Scope of Work for a defined area that has been released for execution by the Construction Contractor
- A detailed Bill of Materials (BOM) specifying all quantities making up the scope of Work released by the CWP.
- A schedule detailing commencement and completion dates for scope of Work released by the CWP.
- Technical requirements, references and information pertinent to the scope of Work released in the CWP.
- Safety considerations with respect to the Work / Risk Assessment.

As Issued-for-Construction (IFC) CWP's are released, the Construction Contractor and/or its lower tier subcontractors shall provide the following:

- Roles and responsibilities for Construction Contractor and Sub-Contractors

- Safety considerations with respect to the Work/Risk Assessment.
- Dedicated, suitably trained WorkFace Planners who have either completed the COAA Fundamentals Course or equivalent Owner-developed course to break the CWP into a series of specific WorkFace Planning work packages called Installation Work Packages (IWP's). These dedicated WorkFace Planners will be accountable to complete and signoff as ready the IWP's before the IWP is released to the crew.
- Dedicated Integration Planner with assigned responsibility to coordinate and lead the efforts of the WorkFace Planners and resolve anticipated conflicts proactively between the different IWP's.
- Dedicated Resource Coordinators with assigned responsibility for areas such as material identification and control, scaffolding, construction equipment, specialty tools, and other resources needed to support the WorkFace Planning effort.
- Experienced personnel including craft supervision to review the scope and completeness of IWP's.
- Work force and leadership to execute IWP's.
- Personnel and systems to report progress and performance of IWP's in an agreed upon format and frequency with the Owner.
- Prepare and maintain detailed schedules and spreadsheets tracking, monitoring, and closing-out IWP's from start to completion of each IWP during the construction phase of the project.
- Provide quality assurance personnel to audit compliance to IWP instructions and requirements

Prior to the CWP's reaching IFC stage, the Construction Contractor and/or its lower tier subcontractors shall develop a preliminary IWP Release Plan for each CWP indicating the approximate size and planned release date for each IWP. The Owner and EPCM Contractor will review the Contractor's IWP Release Plan and Owner shall approve with input from the EPCM Contractor. If Owner or EPCM Contractor has comments on the initial submittal and if requested by Owner, the Construction Contractor will resubmit the IWP Release Plan which will include Owner's and/or EPCM Contractor comments in order to gain Owner's approval. The date of the Contractor's initial submittal of the IWP Release Plan is to be agreed upon between Owner, EPCM Contractor and Construction Contractor during the EDS or preliminary engineering phase of the project.

The EPCM Contractor shall be responsible for the following:

- Review and comments on the Construction Contractor's CWP Release Plan, CWP – EWP alignment and other appropriate items, these comments shall be submitted to



the Owner for review and may be included with the Owners comments and submitted to the Construction Contractor for inclusion to the Plan prior to approval by Owner

- Review the detailed description of the CWP Scope of Work for a defined area and submit comments to Owner for review and may be include with the Owner's Comments and submitted to the Construction Contractor for inclusion in the Plan prior to the release for execution by the Construction Contractor
- Monitor, audit and perform ongoing surveillance on the Construction Contractor's - CWP Release Plan and its execution as requested by Owner
- Review and comments on the Construction Contractor's – IWP Release Plan, comments shall be submitted to the Owner for review and may be included with Owners comments and submitted for inclusion to the Plan prior to approval by Owner
- Monitor, audit and perform ongoing surveillance on the Construction Contractor's – IWP Release Plan and its execution as requested by Owner.

## **WORKFACE PLANNING FOR CONSTRUCTION CONTRACTS**

### **WorkFace Planning**

Owner requires that Construction Contractor implement WorkFace Planning, in accordance with the Construction Owners Association of Alberta (COAA) model as published on the COAA website ([www.coaa.ab.ca](http://www.coaa.ab.ca).) The Construction Contractor shall submit their Workface Execution Plan taking into account the minimum standards of the COAA model contents and Construction Contractor's implementation shall be in accordance with terms and conditions agreed between Owner and Construction Contractor.

The Construction Contractor's WorkFace Planning Execution Plan, complete with a WorkFace Planning Score Card, shall be prepared by the Construction Contractor and submitted to Owner for review and approval no later than 90 days in advance of the beginning of permanent plan installations at the Site or as otherwise agreed.

Construction Contractor shall, or if requested by Owner, conduct periodic audits of its WorkFace Planning efforts including its lower tier subcontractors using the WorkFace Planning Score Card at the frequency and times noted therein. Owner shall monitor and reserves the right at any time deemed necessary to audit using their WorkFace Planning Score Card on the execution of the Construction Contractor's Workface Execution Plan throughout the duration of the contract to determine if WorkFace Planning is being implemented in accordance with the agreed upon Workface Execution Plan. In cases where significant deviations to the Workface Execution Plan are identified either by the Owner or the Construction Contractor, the Construction Contractor shall immediately prepare an action plan for correction of the deficiencies and shall immediately implement this plan upon approval of the owner.

The Construction Contractor will divide a Work Design Area into a series of preferred Construction Work Packages (each a "CWP"). These CWP definitions will be issued to the Owner and Engineering group in order to align relevant portions of the overall scope of Work with the Engineering deliverables e.g.: Engineering Work Packages (EWP's), Materials and Equipment. With Owner participation the Construction Contractor and Engineering Contractor shall discuss and form agreement for mutual benefit with regard to the packaging boundaries. This cooperation shall continue throughout the project to completion.

If EP/EPCM Contractor and Construction Contractor cannot agree on the EWP/CWP breakdown the Owner together with the EP/EPCM Contractor and Construction Contractor will formulate an agreement that is beneficial to the overall project.

During the EDS or preliminary engineering stage of the project, as a result of agreement between the Engineering Contractor and the Construction Contractor, the Construction Contractor will identify the CWP's and develop a CWP Release Plan that will specify the number, approximate manhour size, and preferred release date for each CWP. The CWP Release Plan will include standard templates to be used, the number of packages, and planned craft loading to accomplish the tasks in the CWP's. Construction Contractor shall submit the CWP Release Plan to the Owner for approval and Engineering Contractor for review and comment. If Owner and Engineering Contractor have comments on the initial submittal, and if requested by Owner, the Construction Contractor will resubmit the CWP Release Plan taking into account Owner and Engineering Contractor's comments in order to gain Owner's approval. The date of the Contractor's initial submittal of the CWP Release Plan is to be agreed upon between Owner and Construction Contractor at the beginning of the EDS or preliminary engineering phase.

Each CWP will include but not limited to the following:

- A detailed description of the Scope of Work for a defined area that has been released for execution by the Construction Contractor
- A detailed Bill of Materials (BOM) specifying all quantities making up the Scope of Work released by the CWP
- A schedule detailing commencement and completion dates for Scope of Work released by the CWP
- Technical requirements, references, and information pertinent to the Scope of Work released in the CWP
- Safety considerations with respect to the Work/Risk Assessment.

As Issued-for-Construction (IFC) CWP's are released, the Construction Contractor and/or its lower tier subcontractors shall provide the following:

- Roles and responsibilities of Construction Contractor and Sub-Contractors
- Safety considerations with respect to the Work/Risk Assessment.
- Dedicated, suitably trained WorkFace Planners who have either completed the COAA Fundamentals Course or equivalent Owner-developed course to break the CWP into a series of specific WorkFace Planning work packages called Installation Work Packages

(IWP's). These dedicated WorkFace Planners will be accountable to complete and signoff as ready the IWP's before the IWP is released to the crew.

- Dedicated Integration Planner with assigned responsibility to coordinate and lead the efforts of the WorkFace Planners and resolve anticipated conflicts proactively between the different IWP's.
- Dedicated Resource Coordinators with assigned responsibility for areas such as material identification and control, scaffolding, construction equipment, specialty tools, and other resources needed to support the WorkFace Planning effort.
- Experienced personnel including craft supervision to review the scope and completeness of IWPs.
- Work force and leadership to execute IWP's.
- Personnel and systems to report progress and performance of IWP's in an agreed upon format and frequency with the Owner.
- Prepare and maintain detailed schedules and spreadsheets tracking, monitoring, and closing-out IWP's from start to completion of each IWP during the construction phase of the project.
- Provide quality assurance personnel to audit compliance to IWP instructions and requirements

Prior to the CWP's reaching IFC stage, the Construction Contractor and/or its lower tier subcontractors shall develop a preliminary FIWP Release Plan for each CWP indicating the approximate size and planned release date for each FIWP. The Owner will review the Contractor's FIWP Release Plan and approve. If Owner has comments on the initial submittal and if requested by Owner, the Contractor will resubmit the FIWP Release Plan taking into account Owner's comments in order to gain Owner's approval. The date of the Contractor's initial submittal of the FIWP Release Plan is to be agreed upon between Owner and Contractor during the EDS or preliminary engineering phase of the project.

During the Construction Phase the Construction Contractor may be required to liaise with other Construction Contractors in the WorkFace Planning effort with regard to common Owner supplied commodities e.g.: Scaffold, Cranes, Transportation, etc..

## IWP STRUCTURAL STEEL

PROJECT INFORMATION				
Project Number	IWP Number & Revision Number	All Related CWP & Revision Number	Area/System/Subsystem/Discipline	Work Performed by
1000	IWP 8120-121	CWP 8120-2	Area 8120 - Structural	

AUTHORSHIP AND APPROVALS		
<b>Prepared by</b>		01 NOV 07
<b>Revised By</b>		01 NOV 07
<b>Issued by</b>		01 NOV 07
<b>Released by</b>		
<b>Assigned by</b>		
<b>Reason to Recall</b>		
<b>Completed by</b>		

## Scope

Install bridge crane steel in the Compressor Shelter and access stairway from the Compressor Shelter to the east/west pipe rack. The Compressor Shelter is located in the NE corner of Area 8120. The bridge crane steel runs the entire length of the Compressor Shelter along the north and south walls at approximately elevation 85'. The stairway is at the west end of the Compressor Shelter and runs plant north to the top of the pipe rack. The stairway starts at elevation 85' and goes to elevation 102' at the top of the pipe rack. The platform at elevation 85' is approximately 31' feet above the existing grade with clear access from the west side of the Compressor Shelter.

## Deliverable

- Completed installation of the bridge crane steel in preparation of the bridge crane arrival on 15 Oct 12.
- Complete the stairway installation to allow the ongoing pipe and electrical installation at elevation 102' of the east/west pipe rack.

## Activities

This work represents two (2) weeks of work for the crew.

The structural steel crew will shake out the steel for the described work and stage the materials for delivery to the west end of the Compressor Shelter. This will take two days. The erection team will commence installing approximately 15 tons of bridge crane steel starting at the east end north side then moving to the south side. This will be time consuming work due to the congestion and amount of work that will be performed from manbaskets.

The bolt up crew will start the preassembly of the stair stringers and treads along with the landing platforms at ground level on the west end of the Compressor Shelter. All handrails and grating will be installed at grade.

The bolt up crew will move to the north side bridge crane steel once the erection crew moves to the south side. We will have to watch the movement of the manlifts so as not to interfere with the two work activities on either side of the shelter.

Once erection is complete in the Compressor Shelter the erection team will move on to the installation of the stairway and landing platforms.

A reminder that the sheeting contractor will be working on the outside of the north and south walls while we are doing our erection on the inside.

## Resources

### Equipment (See Construction Equipment Schedule for details)

- 3990T Crane
- 65T Mobile
- 2 – 80 foot manlift
- 3 – flatbed trailers(part time)
- air compressor
- 2 – welding machines
- 4 – 50 retractable connectors
- 4 – 50 retractable connectors

## Tools

- 3 – impact guns
- 1 – mag drill
- 2 – 20' extension ladders
- 200' welding lead
- hammer wrenches – 1 ¼ " and 1 5/8"
- selection of wire slings and shackles

## Materials

- All steel is available in the steel laydown yard reference grid 12B.
- Bolts and nuts; 3X3 shims; grating clips; bridge crane rail hold down brackets; all these items are at the warehouse bagged and tagged reference location row 2 shelf B3.

- 1/2" inch wire rope and Crosby clips

## Labour

- 1 – working foreman;
- 4 – journeyman IW;
- 2 – apprentice;
- 2 – helpers;
- 2 - operators

## Work Instructions

- All manlift operators must have project certification.
- Several pieces of equipment are installed at the east end of the building and must be protected from weld splatter and falling tools. Use scaffolding frames with 5/8 inch plywood and fire blanket to cover the equipment.
- Red flag the selected areas of overhead work.
- Work closely with Jim Siding, foreman for GOOD Enclosures INC, working on the outside of the north wall of the Shelter.

## Safety Equipment

Barricade tape; fire extinguishers; safety harness; and lanyards.

## Drawings

- Compressor Shelter - Isometric View Dwg 8120-stru-112 rev 3;
- Framing Sheets Dwg 8120-stru-113 rev 2 Sheets 1 to 5
- Elevations Dwg 8120-stru-110 rev 2 Sheets 1 to 4
- Stair Sections Dwg 8120-stru-114 rev 1
- Sections & Details Dwg 8120-stru-115 rev 2 Sheets 1 to 3



## Vendor Information

Big Steel Fabricators (BFS) have included all erection drawings with appropriate piece Sepks. They have supplied nuts and bolts with a 10% bump. A set of erection drawings are attached and the nuts and bolts are bagged and tagged in Bin 72/ Row 6 at the main warehouse.

## Special Conditions

- We will be working at heights for a lot of this IWP so take time in the morning and after lunch to reinforce 'working at heights' safety standard.
- Permit required when access to Compressor Shelter is blocked during setting of crane rails.
- The 2 – apprentice have just recently joined the project so they must be teamed with a journeyman while working at heights.

## Quality Control

- All bolts are to be tortured per the project spec 8120-stru-S2 rev 1. Specs including weld procedures are attached.
- Notify Wil Engineer for a spot check on bolt tensioning. CYY Crane Company will inspect all crane rail supports prior to rail installation.

## Interdependencies

This work package is dependent on the availability of 2 – 80' manlifts which are currently being used by electricians running cable tray. One week prior to start of work confirm the availability on the equipment and order short term rental if electrical work is not complete.

## Risk Planning

At this time, there is no known risk that would prevent the work package from proceeding.

## Reverse Punch List (Error Proofing)

- We have recently experienced some quality issues related to bolt tensioning. After each bolt is tensioned the nut will be Sepked with a yellow Sepk to indicate the work is complete.
- We have also had some issues with the BFS's piece Sepks not matching the deliver inventory. Our experience has shown that the piece Sepk on the steel is correct and matches the erection drawing. If this occurs notify Jim Bob Receiver at the warehouse.

## Lessons Learned

To be added at completion of the job. Team meeting to be held with Ron Planner to capture the LL.

## List of Attachments

1. Three Week Area Schedule
2. Construction Equipment Schedule
3. Material Report
4. Weld Procedures
5. Specs
6. Access/Egress Permit
7. Quantity and Unit Rate Report

# Sample: IWP

## -Installation Work Package

**Cooling Water System**  
**Rig in Place 18 Spools**  
**512 Man hours**  
**IWP: L-12-34-015-12345**

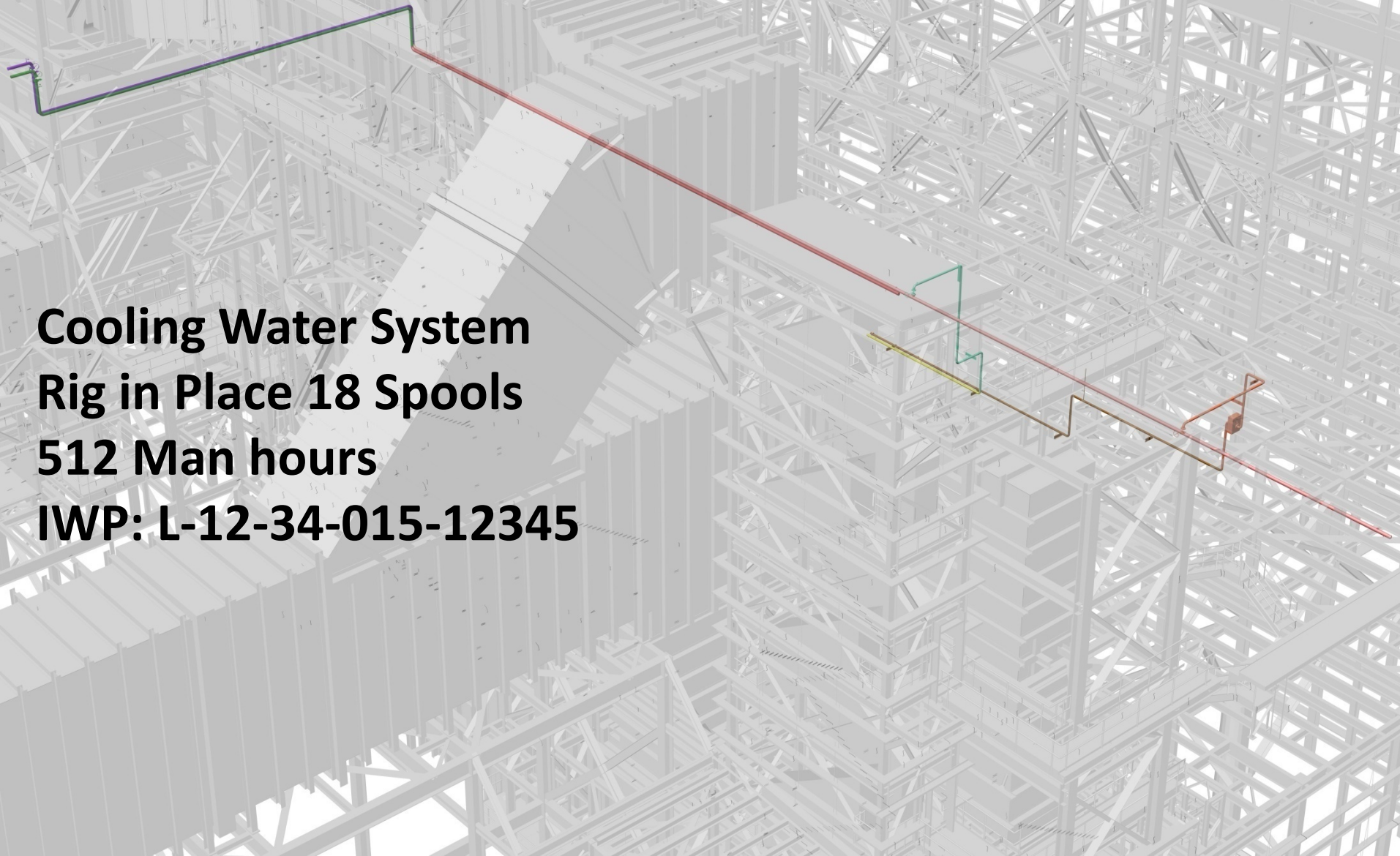

# **Table of Contents**

1. Constraints
2. Scope
3. Safety
4. QA/QC
5. Trade Coordination
6. Material Take Off
7. Scaffold Request
8. Equipment Request
9. IWP Lookahead
10. Timesheets
11. Model Shots and Isos

# 1. Constraints

IWP	L-12-34-015-12345	Cooling Water	Date
Revision	0		
Related to FIWPs	L-12-34-013/014/016	Threaded branches	
Discipline	Pipe		
Permit	Green Field		
Schedule ID	Activity ID P-1234	March 16/ 08 - May 14/08	
WorkFace Planner		Johnny Fitswell	Jan-31
Material Confirmed	Warehouse	Short one set of studs, two shoes	Feb-18
Material Requested	Heather		Mar-17
Required On Site			Mar-31
Scaffold Requested	Req # S-1234		Mar-14
Scaffold Confirmed		Billy Tubnclamp	Mar-24
Equipment Requested	Req # E-2456	60' Manlift, 65 ton crane.	Mar-12
Prerequisites	Civil Complete		Nov-24
	Equipment Set		Jan-12
	Steel Erected		Mar-11

Reviewed by	Comments		
Superintendent			
General Foreman			
Safety Representative			
Quality Control			
Foreman			

Recalled	By:	Reason:	
----------	-----	---------	--

## 2. Scope

Secure in place the 18 spools identified. Install with wire rope and Crosby clamps, hot bolt flange connections in preparation for welding on the next shift. Work is 45' above grade, scaffold has been built for the east end connections. 60' Manlift is booked for the west end connections. 60 ton crane with jib has been reserved for 75% use. 25% Share with the Iron workers in the NE quadrant. – Equipment Coordinator is Ed on Radio channel 12B.

The spools c/w studs nuts and gaskets will be delivered to drop zone # 15 overnight on Sunday Mar 30<sup>th</sup>.

Shorts: One set of 1" studs and two shoes are missing and on back order. Due on Tuesday. Check the rigging trailer to see that there is enough rigging and order any shorts from the tool crib.

Planned Value: 512 hours.

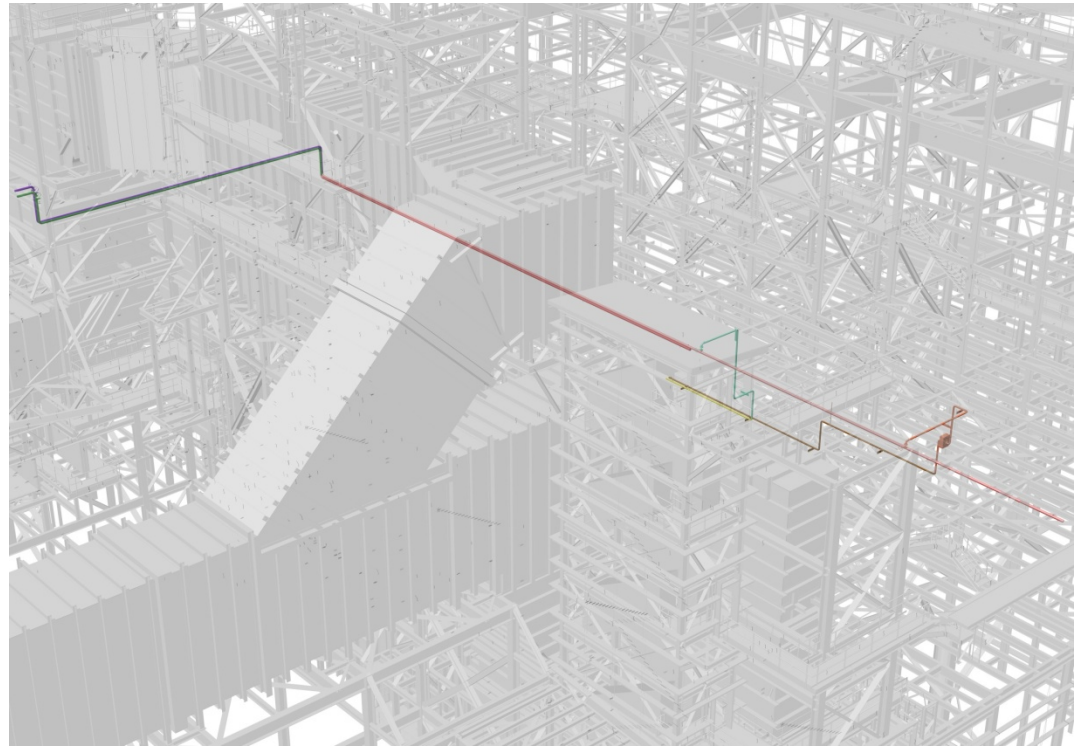

### 3. Safety Review

This work is to be performed at heights from manlifts and scaffolds.

Standard Precautions: Prior to each shift please conduct a tool box safety review. Make mention of the dangers of working at heights and ask for the crew's input on what could be done to reduce or remove any known hazards.

Full body harnesses must be worn at all times with 100% tie off while in the manlifts.

Be aware that the Ironworkers are working in the structure in the NE quadrant. Please coordinate directly with the Forman, Bob Enweave on radio channel 11A.

Execute the Vehicle inspection checklist prior to each operation of the manlift and bring awareness to any other moving pieces of equipment. All manlift operators must be certified.

Please do not use any part of the scaffolds to support or brace rigging.

Have a safe day

Susan Petit

Safety Evangelist.

555-0911

## 4. Quality Review

The rigging of spools has no specific QC requirements, however please make sure that all exposed ends and openings are capped. Care should be used in the handling and storage of the gaskets and the studs and nuts if they are not to be installed immediately.

Please report any damages that occur during the rigging of the spools.

Thanks

Doug

555-6589



## 5. Trade Coordination

This work is high in the pipe rack in the center north end of the project. Ironworkers are scheduled to be working in the NE quadrant. Please coordinate activities with them. Bob Enweave on radio channel 11A.

Boilermakers are working further west and there may be some interruption from them as they set a vessel on Thursday.

Another Pipefitting crew is working to the East, welding spools.

Please use an appropriate amount of red flagging while flying the spools in and then replace it with Yellow caution tape when the imminent danger has passed. This will reduce the amount of impact that you have on other crews.

# 6. Material Take Off



## Pipe Work Pack - Spools List



ConstructSim

**Work Package: IWP: L-12-34-015-12345**

Spool ID	ISO	Sheet	Rev	Bore	Material	Spec	Area	Service	Sys	QTY	UOM
SPOOL ISO-L-66K130-1A	ISO-L-66K130-1		0	12"	CS	UB-11S	ISO	K		14.42	LF
SPOOL ISO-L-66K130-1B	ISO-L-66K130-1		0	12"	CS	UB-11S	ISO	K		2.98	LF
SPOOL ISO-L-66K130-1C	ISO-L-66K130-1		0	12"	CS	UB-11S	ISO	K		27.82	LF
SPOOL ISO-L-66K130-1D	ISO-L-66K130-1		0	12"	CS	UB-11S	ISO	K		12.46	LF
SPOOL ISO-L-66K81-1A	ISO-L-66K81-1		0	12"	CS	UB-11S	ISO	K		14.41	LF
SPOOL ISO-L-66K81-1B	ISO-L-66K81-1		0	12"	CS	UB-11S	ISO	K		2.98	LF
SPOOL ISO-L-66K81-1C	ISO-L-66K81-1		0	12"	CS	UB-11S	ISO	K		27.82	LF
SPOOL ISO-L-66K81-1D	ISO-L-66K81-1		0	12"	CS	UB-11S	ISO	K		12.46	LF
SPOOL ISO-L-66LS16-1A	ISO-L-66LS16-1		0	16"	CS	INST_IT	ISO	LS		33.60	LF
SPOOL ISO-L-66LS16-2A	ISO-L-66LS16-2		0	16"	CS	SB-1	ISO	LS		9.39	LF
SPOOL ISO-L-66LS16-2B	ISO-L-66LS16-2		0	16"	CS	SB-1	ISO	LS		0.70	LF
SPOOL ISO-L-66LS3-1A	ISO-L-66LS3-1		0	16"	CS	INST_IT	ISO	LS		33.59	LF
SPOOL ISO-L-66LS3-2A	ISO-L-66LS3-2		0	16"	CS	SB-1	ISO	LS		7.60	LF
SPOOL ISO-L-66LS3-2B	ISO-L-66LS3-2		0	16"	CS	SB-1	ISO	LS		0.70	LF



## Pipe Work Pack - Field Materials



ConstructSim

**Work Package: IWP: L-12-34-015-12345**

ISO	Sht	Rev	Mat'l Code	BOM Description	Bore	Mat'l Spec	Qty	UOM
ISO-L-66K130-1	0	_0		BLIND FLANGE RF FS A105-N	0.75	CS UB-11S	1	EA
ISO-L-66K130-1	0	_2		STUD BOLTS c/w 2 NUTS A193-B7 / A194-2H	0.5	CS UB-11S	8	EA
ISO-L-66K130-1	0	_2		STUD BOLTS c/w 2 NUTS A193-B7 / A194-2H	0.5	CS UB-11S	16	EA
ISO-L-66K130-1	0	_2		STUD BOLTS c/w 2 NUTS A193-B7 / A194-2H	0.5	CS UB-11S	48	EA
ISO-L-66K130-1	0	_1		GASKET 1/8 in THK SP WND 304SS GRAPHITE FILLED CS CR	12	CS UB-11S	4	EA
ISO-L-66K130-1	0	_1		GASKET 1/8 in THK SP WND 304SS GRAPHITE FILLED CS CR	0.75	CS UB-11S	2	EA
ISO-L-66K130-1	0	_14		GASKET 1/8 in THK SP WND 304SS GRAPHITE FILLED CS CR CS I/R	18	CS UB-11S	1	EA
ISO-L-66K130-1	0	_13		GENERAL PIPE LUG 66PS-109	12	CS UB-11S	1	EA
ISO-L-66K130-1	0	SUPBS-12		SPECIAL SUPPORT 66SP-59	12	CS UB-11S	1	EA
ISO-L-66K130-1	0	SUPBS-18		SPECIAL SUPPORT 66SP-61	18	CS UB-11S	1	EA
ISO-L-66K130-1	0	SUPBS-18_1		SPECIAL SUPPORT 66SP-60	18	CS UB-11S	1	EA

ISO	Sht	Rev	Mat'l Code	BOM Description	Bore	Mat'l Spec	Qty	UOM
ISO-L-66K130-1	0		K_2	GATE VALVE RF FLGD BB OS&Y c/w GEAR OPERATOR NACE STANDARD A216GR WCB	12	CS UB-11S	1	EA
ISO-L-66K130-1	0		V-1.0.1F.1.12-N	GATE VALVE RF FLGD BB OS&Y NACE STANDARD A105-N	0.75	CS UB-11S	1	EA
ISO-L-66K81-1	0		_0	BLIND FLANGE RF FS A105-N	0.75	CS UB-11S	1	EA
ISO-L-66K81-1	0		_2	STUD BOLTS c/w 2 NUTS A193-B7 / A194-2H	0.5	CS UB-11S	48	EA
ISO-L-66K81-1	0		_2	STUD BOLTS c/w 2 NUTS A193-B7 / A194-2H	0.5	CS UB-11S	8	EA
ISO-L-66K81-1	0		_2	STUD BOLTS c/w 2 NUTS A193-B7 / A194-2H	0.5	CS UB-11S	16	EA
ISO-L-66K81-1	0		_1	GASKET 1/8 in THK SP WND 304SS GRAPHITE FILLED CS CR	12	CS UB-11S	4	EA
ISO-L-66K81-1	0		_1	GASKET 1/8 in THK SP WND 304SS GRAPHITE FILLED CS CR	0.75	CS UB-11S	2	EA
ISO-L-66K81-1	0		_14	GASKET 1/8 in THK SP WND 304SS GRAPHITE FILLED CS CR CS I/R	18	CS UB-11S	1	EA
ISO-L-66K81-1	0		_13	GENERAL PIPE LUG 66PS-109	12	CS UB-11S	1	EA
ISO-L-66K81-1	0		SUPBS-12	SPECIAL SUPPORT 66SP-85	12	CS UB-11S	1	EA
ISO-L-66K81-1	0		SUPBS-18	SPECIAL SUPPORT 66SP-83	18	CS UB-11S	1	EA
ISO-L-66K81-1	0		SUPBS-18_1	SPECIAL SUPPORT 66SP-84	18	CS UB-11S	1	EA
ISO-L-66K81-1	0		K_1	GATE VALVE RF FLGD BB OS&Y c/w GEAR OPERATOR NACE STANDARD A216GR WCB	12	CS UB-11S	1	EA
ISO-L-66K81-1	0		V-1.0.1F.1.12-N	GATE VALVE RF FLGD BB OS&Y NACE STANDARD A105-N	0.75	CS UB-11S	1	EA
ISO-L-66LS16-1	0				1.5	CS INST_1 TEMS	0.41	LF

ISO	Sht	Rev	Mat'l Code	BOM Description	Bore	Mat'l Spec	Qty	UOM	
ISO-L-66LS16-1		0			1.5	CS	INST_I TEMS	0.41	LF
ISO-L-66LS16-1		0	_0	FLOW ELEMENT CL300 (BY INSTRUMENTATION)	1.5	CS	INST_I TEMS	1	EA
ISO-L-66LS16-1		0			1.5	CS	INST_I TEMS	0.82	LF
ISO-L-66LS16-1		0	SUPBS-16	SPECIAL SUPPORT 66PS-70	16	CS	INST_I TEMS	1	EA
ISO-L-66LS16-2		0	_9	STUD BOLTS c/w 2 NUTS A193-B7 / A194-2H	0.5	CS	SB-1	16	EA
ISO-L-66LS16-2		0	_9	STUD BOLTS c/w 2 NUTS A193-B7 / A194-2H	0.5	CS	SB-1	16	EA
ISO-L-66LS16-2		0	_8	GASKET 1/8 in THK SP WND 304SS GRAPHITE FILLED CS CR	16	CS	SB-1	3	EA
ISO-L-66LS16-2		0	_0	PLUG THRD HEX HD FS A105-N	0.75	CS	SB-1	1	EA
ISO-L-66LS16-2		0	_10	PADDLE BLIND RF C/W SPACER PER ASME B16.48 A516 GR 70-N	16	CS	SB-1	1	EA
ISO-L-66LS3-1		0			1.5	CS	INST_I TEMS	0.4	LF
ISO-L-66LS3-1		0			1.5	CS	INST_I TEMS	0.4	LF
ISO-L-66LS3-1		0	_0	FLOW ELEMENT CL300 RF FLG (BY INSTRUMENTATION)	1.5	CS	INST_I TEMS	1	EA
ISO-L-66LS3-1		0			1.5	CS	INST_I TEMS	0.8	LF
ISO-L-66LS3-2		0	_9	STUD BOLTS c/w 2 NUTS A193-B7 / A194-2H	0.5	CS	SB-1	16	EA
ISO-L-66LS3-2		0	_9	STUD BOLTS c/w 2 NUTS A193-B7 / A194-2H	0.5	CS	SB-1	16	EA
ISO-L-66LS3-2		0	_8	GASKET 1/8 in THK SP WND 304SS GRAPHITE FILLED CS CR	16	CS	SB-1	3	EA
ISO-L-66LS3-2		0	_0	PLUG THRD HEX HD FS A105-N	0.75	CS	SB-1	1	EA
ISO-L-66LS3-2		0	_10	PADDLE BLIND RF C/W SPACER PER ASME B16.48 A516 GR 70-N	16	CS	SB-1	1	EA

## 7. Copy of Scaffold Request

Date: March 14

Request # S-1234

Requestor: Johnny Fitswell

IWP: L-12-34-015-12345

Required by: Mar 23<sub>rd</sub>

Projected end date: June 30

Description: North central area of the project at EL 141'.

Three scaffold as discussed for access at connection points, see 3D snap shot.

Will be then used for welding in the next month.

Status: Confirmed Mar 24

Billy Tubnclamp.

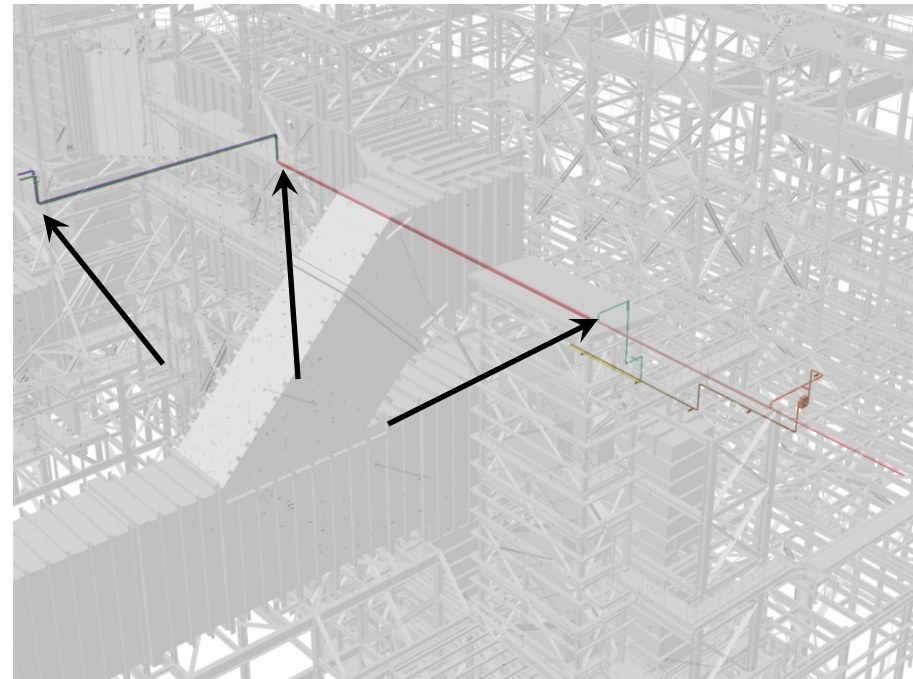

## 8. Copy of Equipment Request

Date: March 12

Request # E-2456

Requestor: Johnny Fitswell

IWP: L-12-34-015-12345

Required on: Mar 31<sub>st</sub> – April 4<sub>th</sub>

Equipment requested: 100% of a 60' manlift

75% of a 65 ton crane with a jib.

Scope: Rigging in 18 x 4" and 6" spools in the North central area of the project.  
Once rigged into place the spools will be lashed with wire rope rigging.

Final alignment will be completed  
without the crane.

Status: Confirmed Mar 12  
B.J. Counterweight

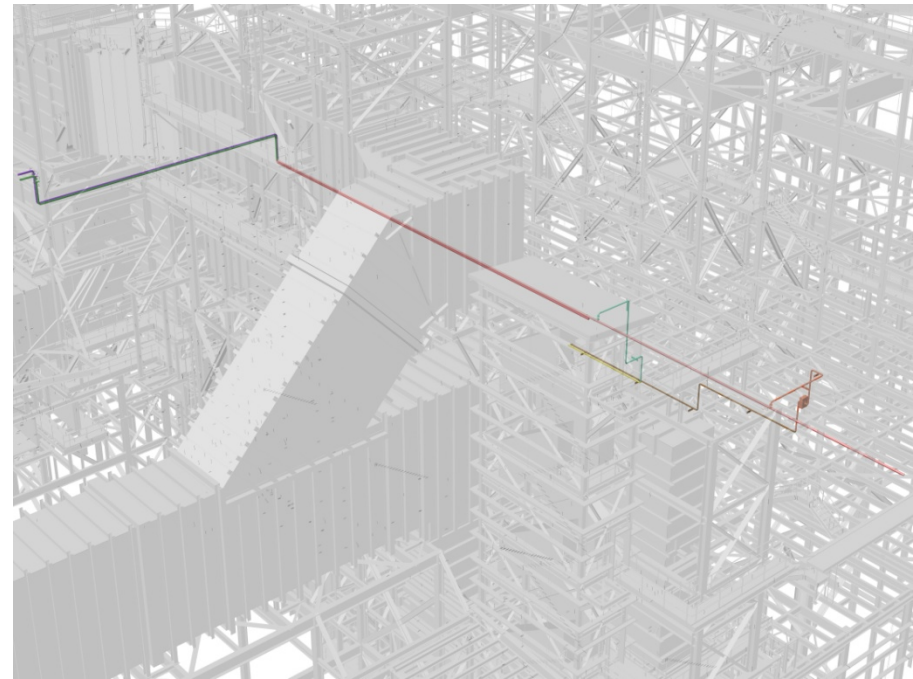

# ConstructSim - Lookahead Planning

Work Pack ID Rig L12-34-015-12345

Plan Start Date  Bdgt Hrs  Bdgt Qty   
 Superintendent Super1  Earn Hrs  Earn Qty   
 Foreman Foreman2

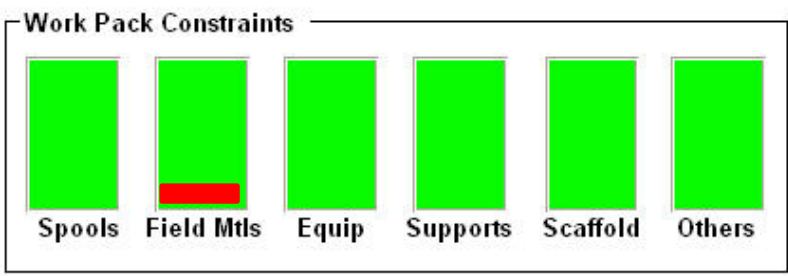

Set Work Pack Type: Pipe::Install

Set View: 8-Week Lookahead

- L12-34-017-24578
- L12-34-011-12345
- L12-34-012-12345
- L12-34-013-12345
- L12-34-014-12345
- L12-34-015-12345**
- L12-34-018-12345
- L12-34-023-12345
- L12-34-028-12345
- L12-34-029-12345

3/31/2008		4/7/2008		4/14/2008		4/21/2008	
WorkPack ID	Hrs	WorkPack ID	Hrs	WorkPack ID	Hrs	WorkPack ID	Hrs
L12-34-012-12345	564	L12-34-022-24578	358	L12-34-019-24578	411	L12-34-026-24578	
L12-34-013-12345	498	L12-34-014-12345	518	L12-34-020-24578	378	L12-34-028-12345	
<b>L12-34-015-12345</b>	<b>512</b>	L12-34-021-24578	526	L12-34-011-12345	587	L12-34-029-12345	
L12-34-017-24578	524	L12-34-018-12345	486	L12-34-023-12345	562	L12-34-025-24578	
Total Hrs 2098		Total Hrs 1888		Total Hrs 1938		Total Hrs	



Crew #		Daily Time Sheet				
Foreman		HOURS WORKED			TOTAL	
EMPLOYEE NO.	NAME	Trade	L-12-34-015-12345	L-12-34-015-12346	Straight Time	Over Time
		TOTALS				

Description of work

APPROVALS

L-12-34-015-12345 - Small bore Carbon Steel - Rigging

L-12-34-015-12346 Small bore carbon steel - Connecting

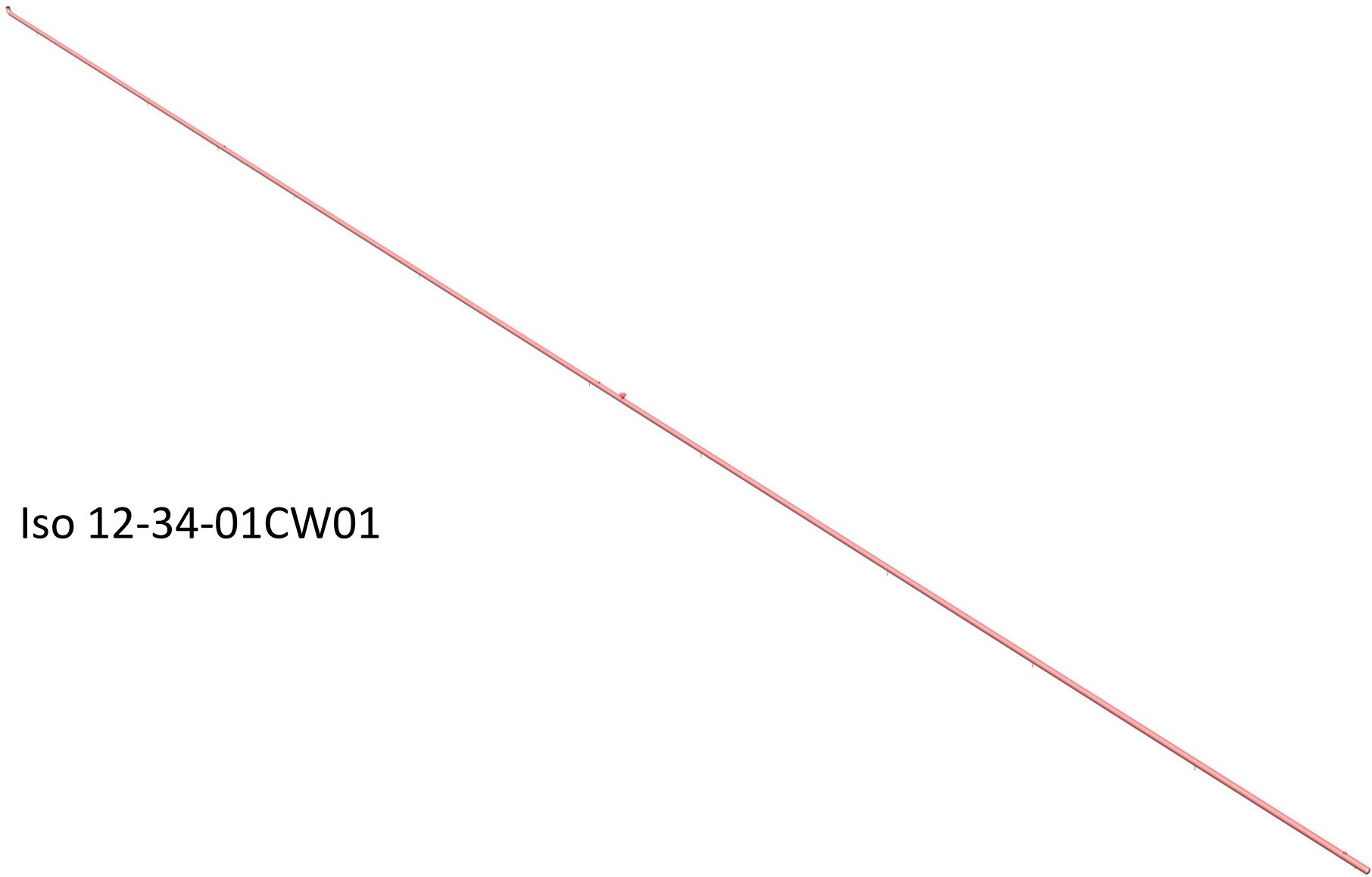

Iso 12-34-01CW01

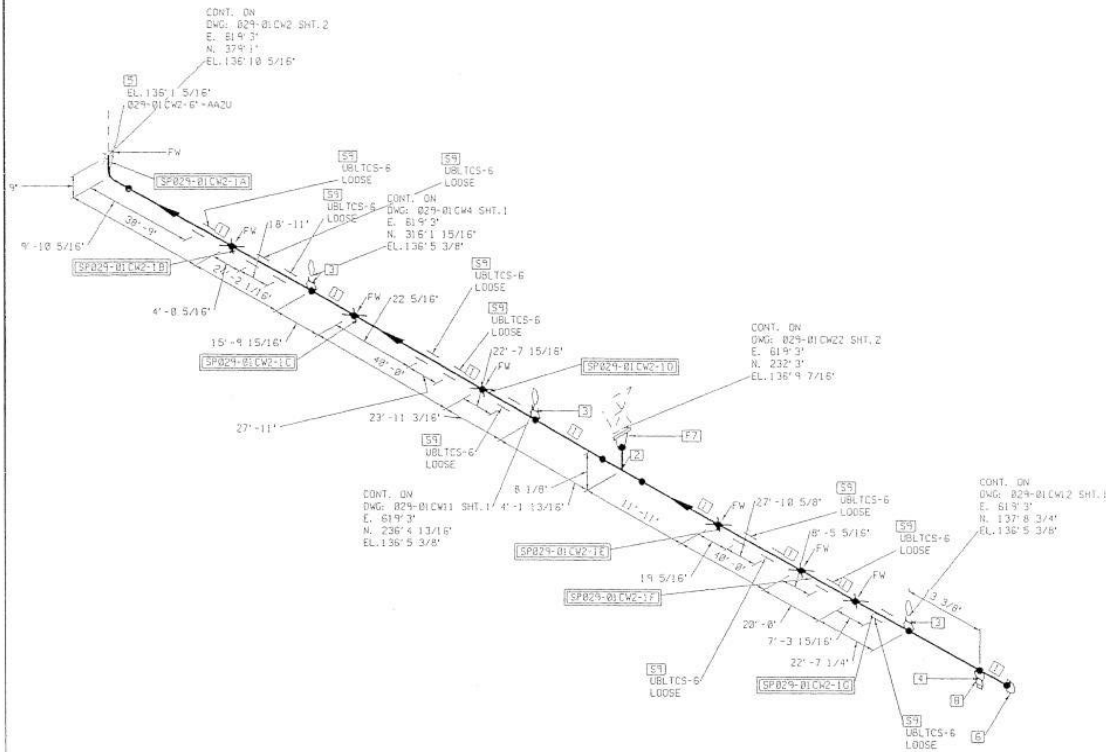

ISOMETRIC NO. 02901CW21

SHOP BILL OF MATERIAL				
NO.	CODE	DESCRIPTION	SIZE	QTY
1	LPW1055	PIPE, ERW, STD WT, BE, SA53 B.	6	241'10"
2	LFW21091	TEE, RED, STD WT, BW, SA234 WPB.	6X4	1
3	L0LT1209	THREDOLET, CL 3000, THD, SA105.	6X2	3
4	L0LT1209	THREDOLET, CL 3000, THD, SA105.	6X3/4	1
5	LFW1089	ELBDW, 90, LR, STD WT, BW, SA234 WPB.	6	1
6	LFWC1094	CAP, STD WT, BW, SA234 WPB.	6	1
7	LLFW1205	FLANGE, WN, CL 150, RF, STD WT, SA105.	4	1

FIELD BILL OF MATERIAL				
NO.	CODE	DESCRIPTION	SIZE	QTY
8	LFTP1084	PLUG, HEX BULL. THD, SA234 WPB-59.	3/4	1
<b>SUPPORTS</b>				
9	UBLTCS-6	U-BOLTS, CS, 0.5 INCH THRU 24 INCHES, SD-000-200-L-630-178.	6	10
<b>SPOOL NUMBERS</b>				
SP029-01CW2-1A	SP029-01CW2-1B	SP029-01CW2-1C	SP029-01CW2-1D	
SP029-01CW2-1E	SP029-01CW2-1F	SP029-01CW2-1G		

PERMIT STAMP

Iso 12-34-01CW02

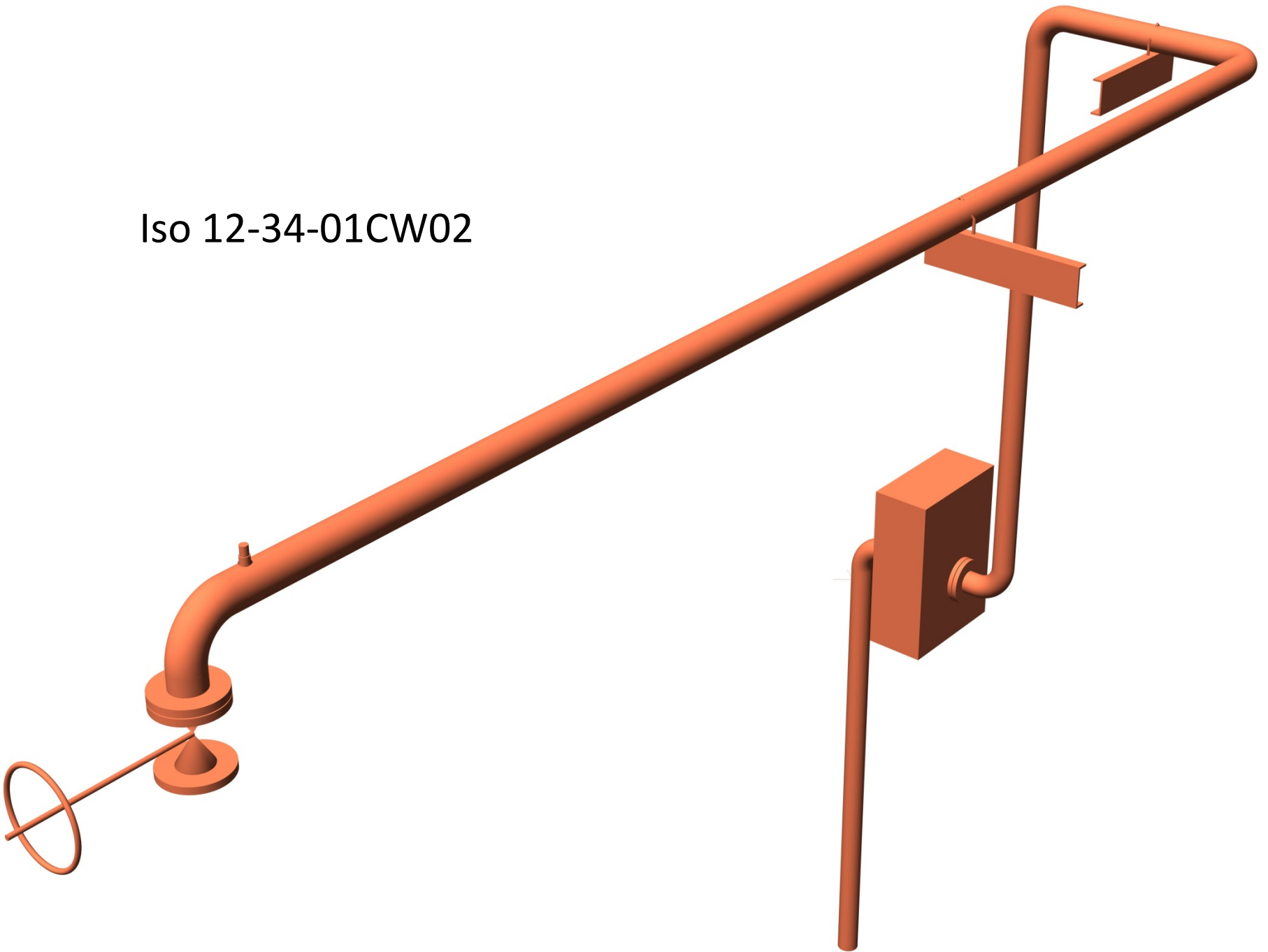

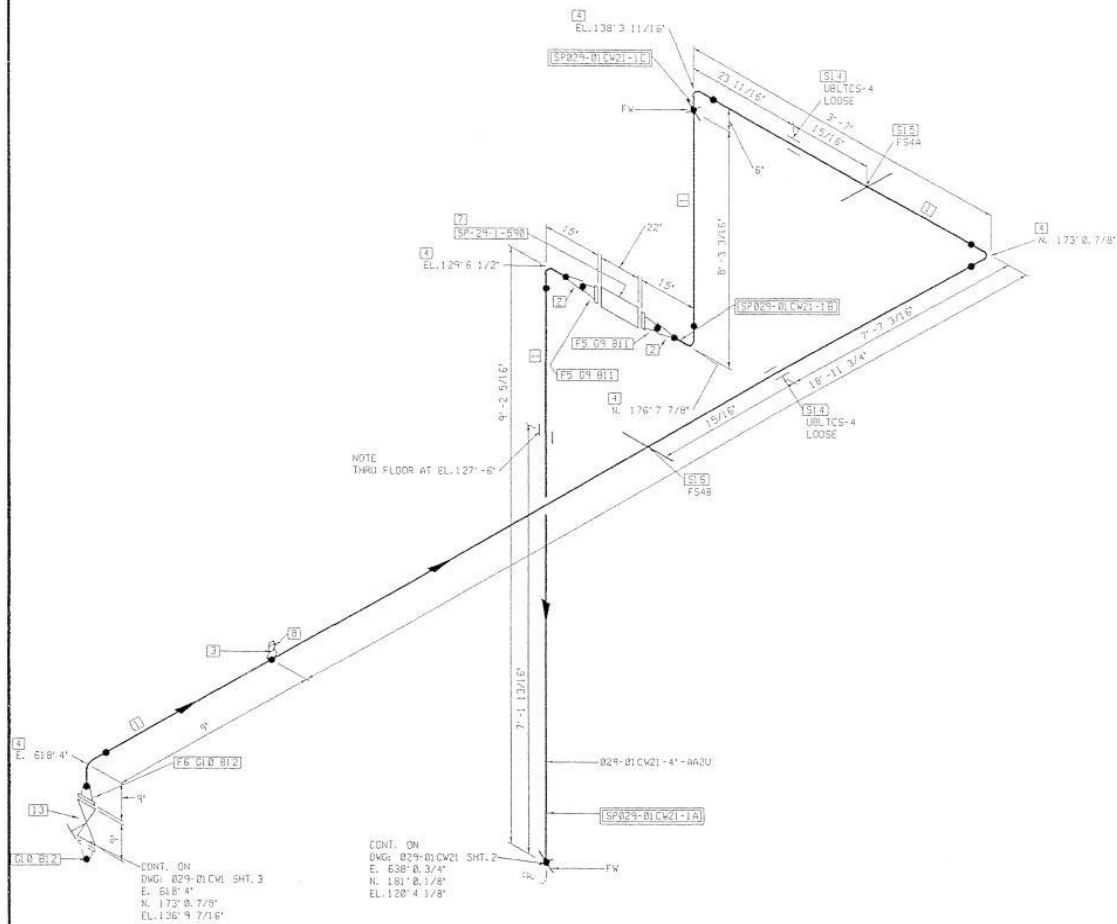

SHOP BILL OF MATERIAL				
NO.	CODE	DESCRIPTION	SIZE	QTY
1	LPWR1055	PIPE, ERW, STD WT, BE, SA53 B.	4	37'10"
2	LPWR1092	REDUCER, CONC. STD WT, BW, SA234 WPB.	6X4	2
3	LOLT1209	THREDDLET, CL 3000, THD, SAI05.	4X3/4	1
4	LFWI039	ELBOW, 90, LR, STD WT, BW, SA234 WPB.	4	5
5	LLFWI205	FLANGE, WN, CL 150, RF, STD WT, SAI05.	6	2
6	LLFWI205	FLANGE, WN, CL 150, RF, STD WT, SAI05.	4	1
FIELD BILL OF MATERIAL				
NO.	CODE	DESCRIPTION	SIZE	QTY
7	SP-29-1-590	1" DUPLEX STRAINER	6	1
8	LFTP1084	PLUG, HEX BULL, THD, SA234 WPB-S9.	3/4	1
9	LGBS1216	GASKET, SP WD, CL 150, 1/8", 304 SS/DRAPIHTE.	6	2
10	LGBS1216	GASKET, SP WD, CL 150, 1/8", 304 SS/DRAPIHTE.	4	2
11	LGB31113	BOLT, STUD, A193 B7 W2 A194 2H NUTS, 4.0" BOLT LENGTH	3/4	16
12	LGB31113	BOLT, STUD, A193 B7 W2 A194 2H NUTS, 3.5" BOLT LENGTH	5/8	16
13	LVGR1358	VALVE, GATE, CL 150, RF, A216 WCB, TRIM B, CAT. 2.	4	1
SUPPORTS				
14	UBLTCS-4	U-BOLTS, CS, 0.5 INCH THRU 24 INCHES, SO-000-000-L-630-178.	4	2
15	FS4A	FIELD SUPPORTS, STEEL, 3 INCHES THRU 12 INCHES, SO-000-000-L-630-210.	4	1
16	FS4B	FIELD SUPPORTS, STEEL, 3 THRU 12 INCHES PIPE SIZES, SO-000-000-L-630-51.	4	1
SPOOL NUMBERS				
SP029-01CW21-1A		SP029-01CW21-1B SP029-01CW21-1C		
<div style="border: 1px solid black; width: 100px; height: 40px; margin: 0 auto;"></div> PERMIT STAMP				

ISOMETRIC NO. 02901CW2II

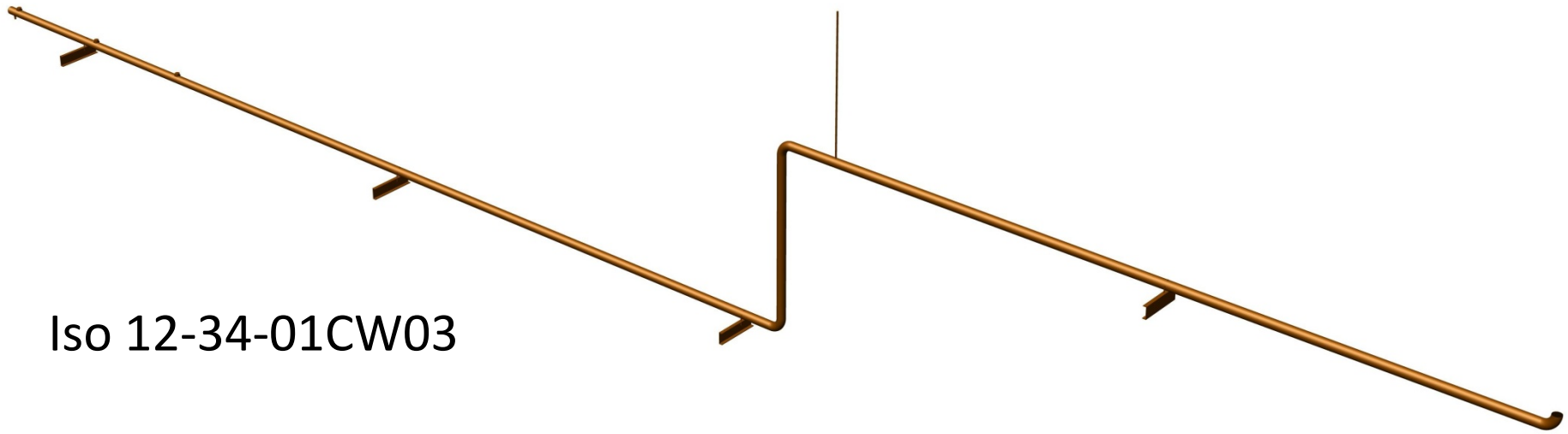

Iso 12-34-01CW03

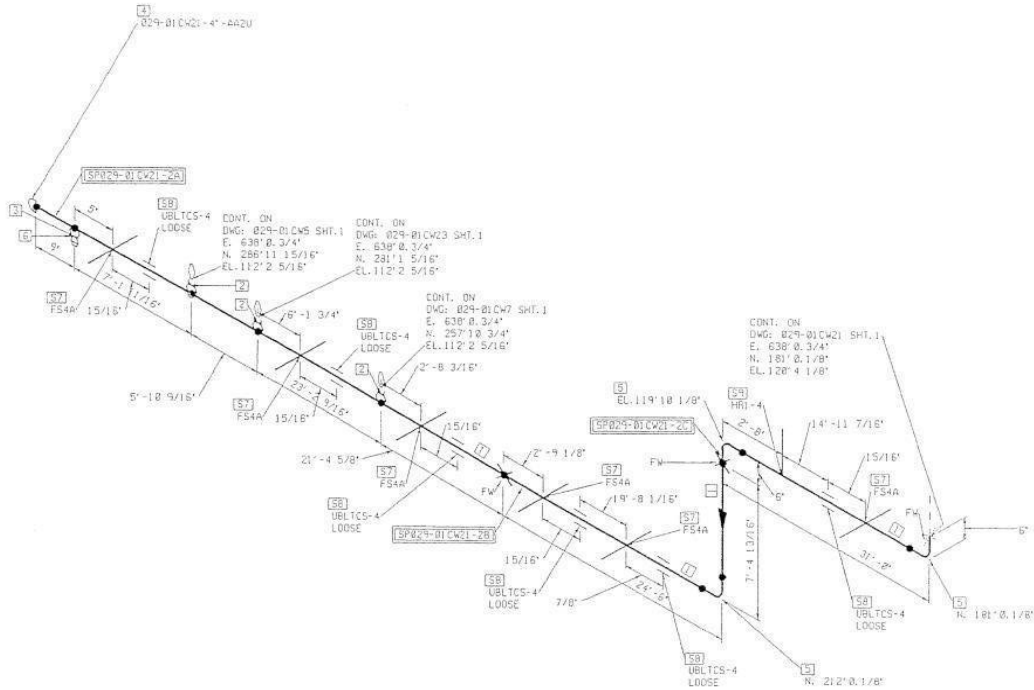

SHOP BILL OF MATERIAL

NO.	CODE	DESCRIPTION	SIZE	QTY
1	LPW1055	PIPE, ERW, STD WT, BE, SA53 B,	4	119'4"
2	LQ11209	THREDDLET, CL 3000, THD, SA105,	4X2	3
3	LQ11209	THREDDLET, CL 3000, THD, SA105,	4X3/4	1
4	LFWC1094	CAP, STD WT, BW, SA234 WPB,	4	1
5	LFW1089	ELBOW, 90, LR, STD WT, BW, SA234 WPB,	4	3

FIELD BILL OF MATERIAL

NO.	CODE	DESCRIPTION	SIZE	QTY
6	LFTPI064	PLUG, HEX BULL. THD, SA234 WPB-S9,	3/4	1
<u>SUPPORTS</u>				
7	FS4A	FIELD SUPPORTS, STEEL, 3 INCHES THRU 12 INCHES, SD-000-000-L-630-21.0,	4	6
8	UBLTCS-4	U-BOLTS, CS, Ø.5 INCH THRU 24 INCHES, SD-000-000-L-630-21.7B,	4	16
9	HR1-4	HANGER ROD & PIPE CLAMP, SD-000-000-L-630-21.7,	4	1

SPOOL NUMBERS

SP029-01CW21-24 SP029-01CW21-28 SP029-01CW21-2C

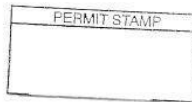

Iso 12-34-01CW04

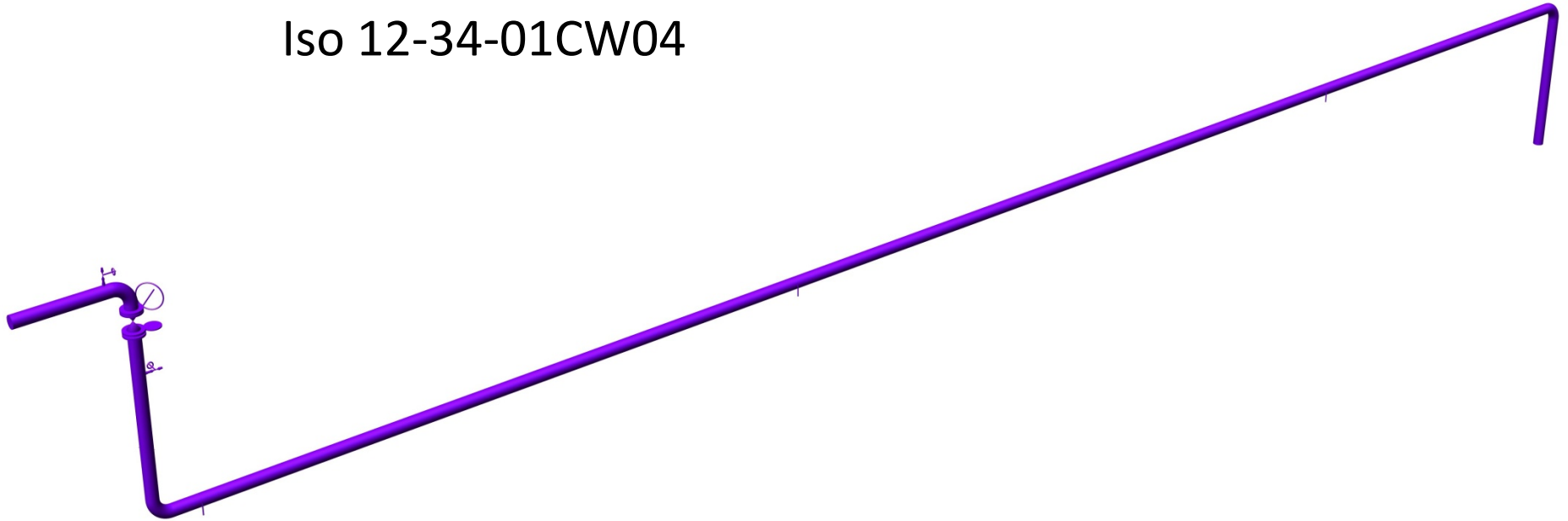



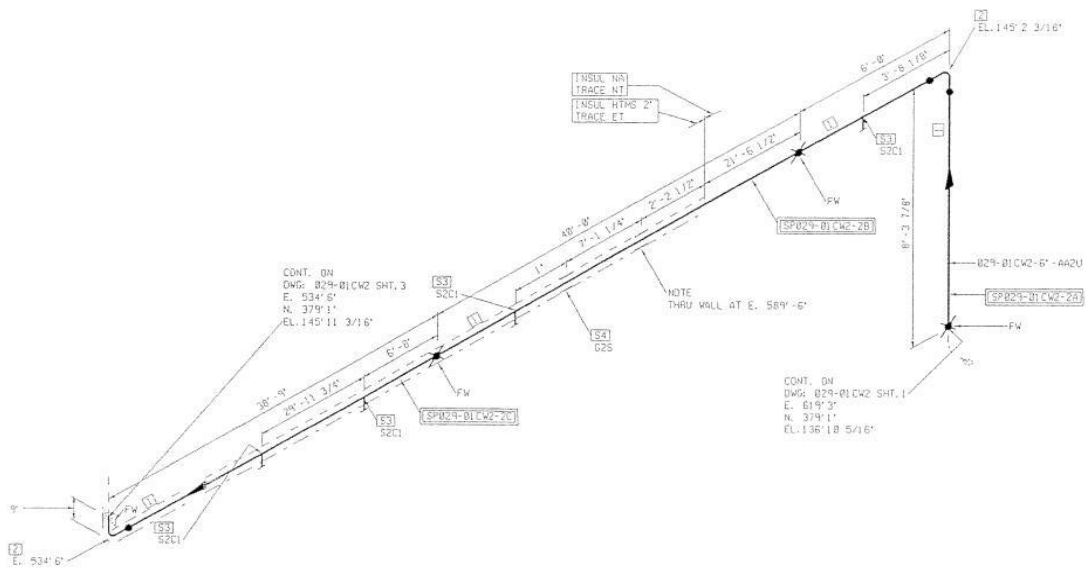

SHOP BILL OF MATERIAL				
NO.	CODE	DESCRIPTION	SIZE	QTY
1	LPWR1055'	PIPE, ERW, STD WT., BE, SA53 B.	6"	90' 10"
2	LFWR1059'	ELBOW, 90, LR, STD WT., BW, SA234 WPB.	6"	2
SUPPORTS				
3	S2C1	SHOE, CS, 3 INCHES THRU 10 INCHES PIPE, SD-000-000-L-630-153.	6"	4

FIELD BILL OF MATERIAL				
NO.	CODE	DESCRIPTION	SIZE	QTY
SUPPORTS				
4	G2S	GUIDES, WITH SHOE, HORIZONTAL LINES, SD-000-000-L-630-97.	6"	1
SPDOL NUMBERS				
SP029-01CW2-2A SP029-01CW2-2B SP029-01CW2-2C				

PERMIT STAMP

Iso 12-34-01CW05

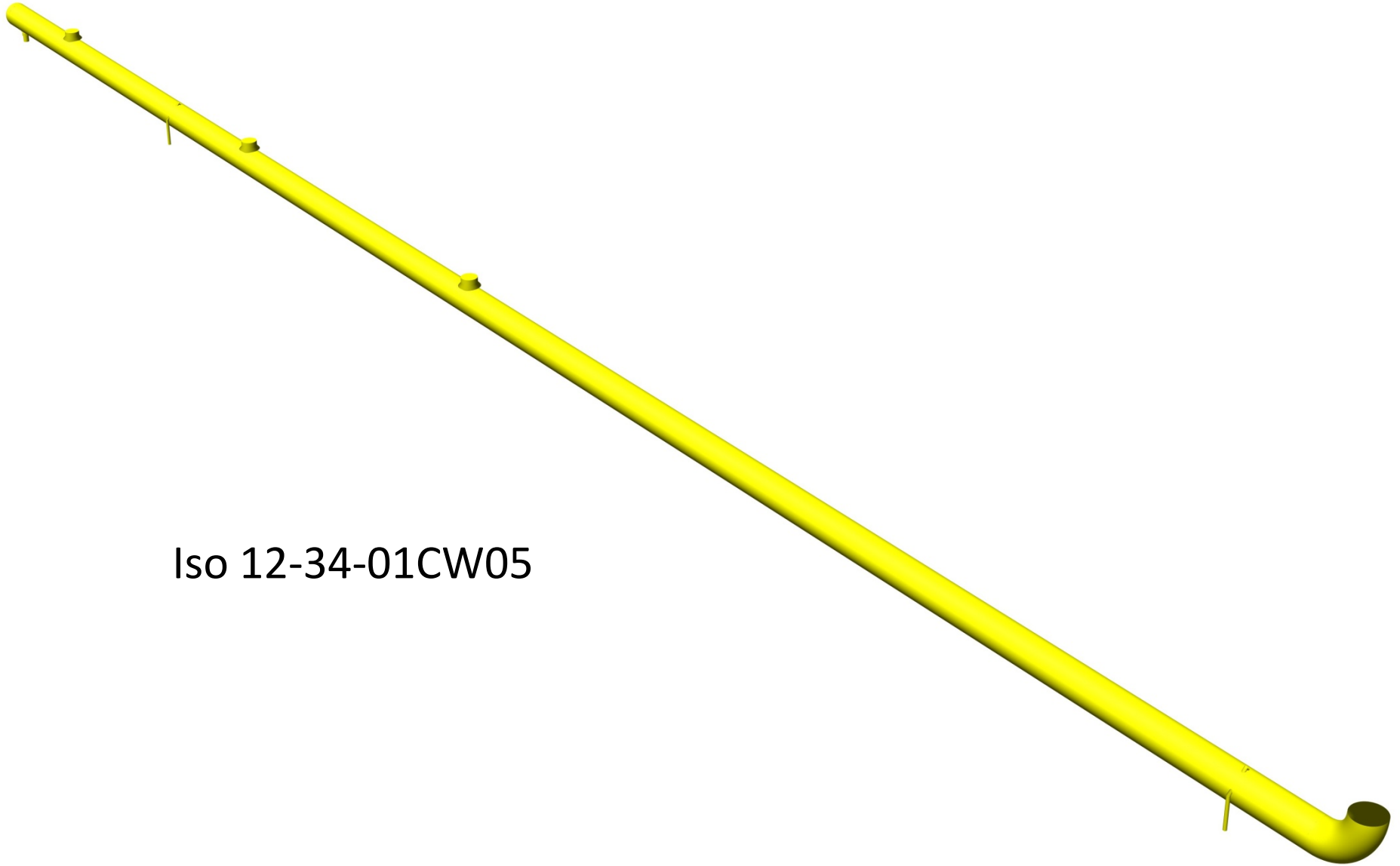

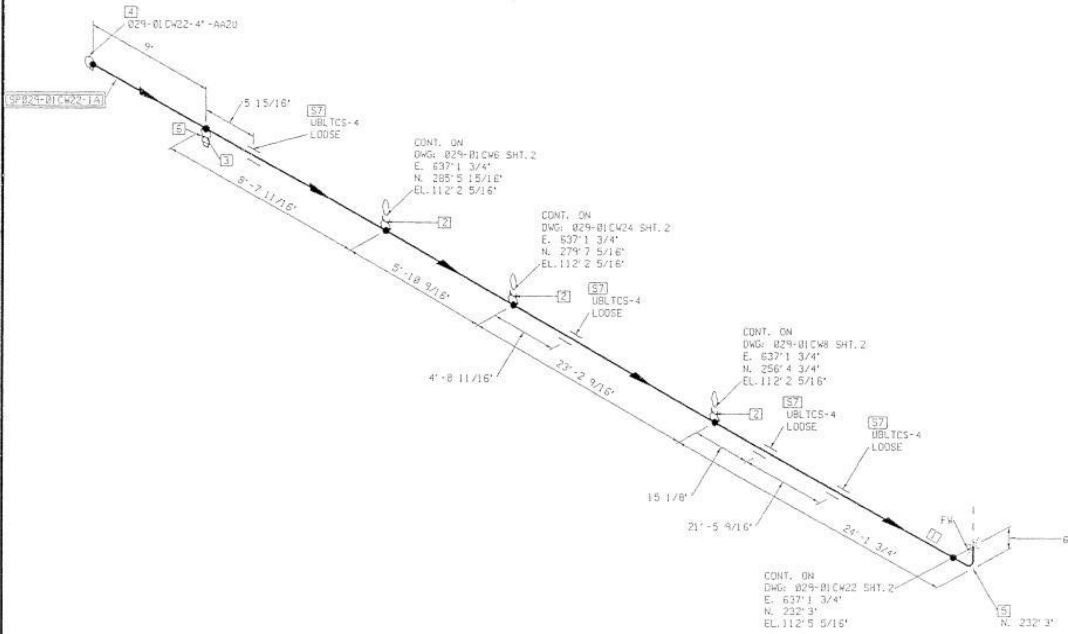

ISOMETRIC NO. 02901CW22

SHOP BILL OF MATERIAL

NO.	CODE	DESCRIPTION	SIZE	QTY
1	LPWR1055	PIPE, ERW, STD WT, SE, SA53 B.	4	62' 2"
2	LOLT1209	THRODLET, CL 3000, THD, SA105.	4X2	3
3	LOLT1209	THRODLET, CL 3000, THD, SA105.	4X3/4	1
4	LFWC1094	CAP, STD WT, BK, SA234 WFB.	4	1
5	LPWR1089	ELBOW, 90, LR, STD WT, BK, SA234 WFB.	4	1

FIELD BILL OF MATERIAL

NO.	CODE	DESCRIPTION	SIZE	QTY
6	LFTP1084	PLUG, HEX BULLY THD, SA234 WFB-S9.	3/4	1

SUPPORTS

7	UBLTCS-4	U-BOLTS, CS, 0.5 INCH THRU 24 INCHES, SD-000-000-L-630-178.	4	4
---	----------	---	---	---

SPOOL NUMBERS

SP029-B1CW22-1A

PERMIT STAMP

DATE: 11/15/01 11:51 AM

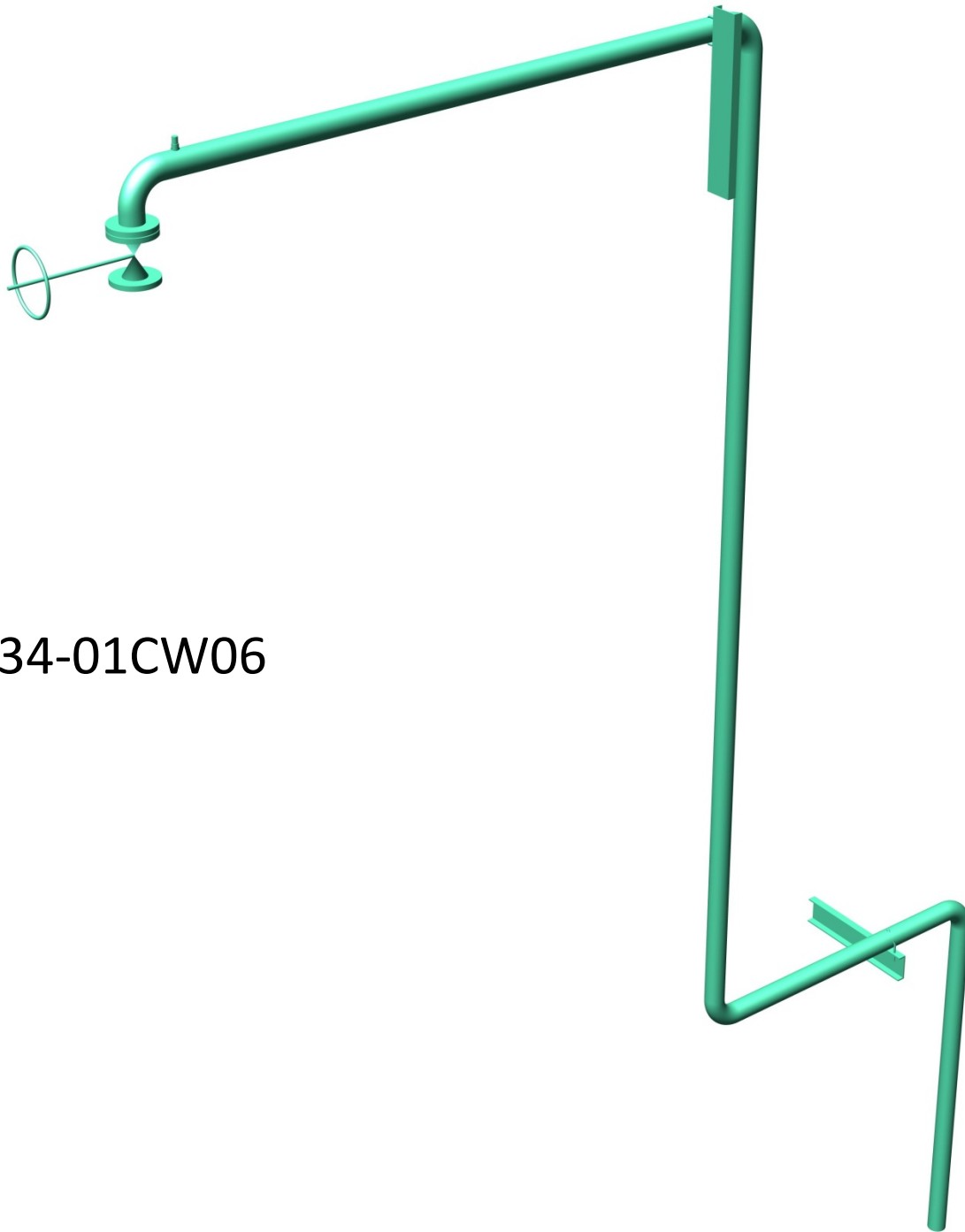

Iso 12-34-01CW06

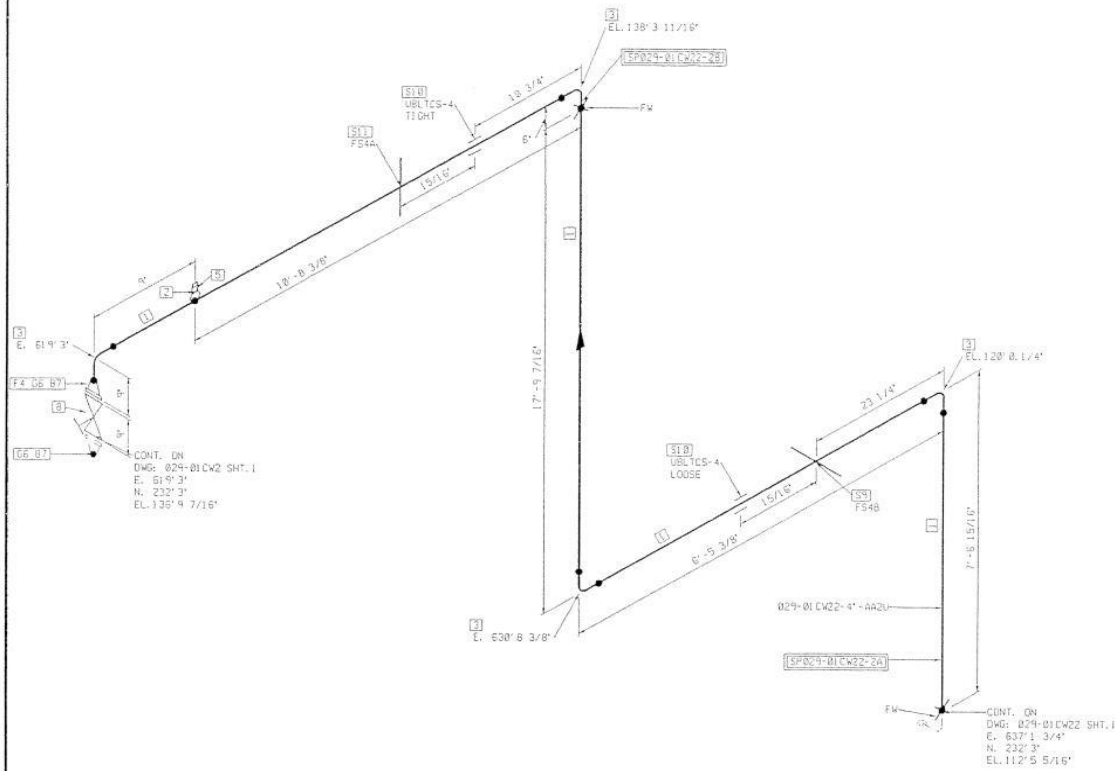

ISOMETRIC NO. 02901CW22

SHOP BILL OF MATERIAL

NO.	CODE	DESCRIPTION	SIZE	QTY
1	LPWR1055	PIPE, ERW, STD WT., 80, SA53 B.	4	40' 4"
2	LOLT1209	THRODLET, CL 3000, THD, SA105.	4x3/4	1
3	LFWR1089	ELBOW, 90, LR, STD WT., 8W, SA234 WPB.	4	4
4	LLFW1205	FLANGE, WN, CL 150, RF, STD WT., SA105.	4	1

FIELD BILL OF MATERIAL

NO.	CODE	DESCRIPTION	SIZE	QTY
5	LFTP1084	PLUG, HEX BULL, THD, SA234 WPB-59.	3/4	1
6	LGES1216	GASKET, SP WD, CL 150, 1/8", 304 SS/GRAPHITE.	4	2
7	LGR31113	BOLT, STUD, A193 B7 W/2 A194 2H NUTS, 3.5" BOLT LENGTH	5/8	16
8	LVGR1358	VALVE, GATE, CL 150, RF, A216 WCB, TRIM 8, CAT. 2.	4	1

SUPPORTS

9	FS4B	FIELD SUPPORTS, STEEL, 3 THRU 12 INCHES PIPE SIZES, SD-000-000-L-630-51.	4	1
10	UBLTCS-4	U-BOLTS, CS, 0.5 INCH THRU 24 INCHES.	4	2
11	FS4A	FIELD SUPPORTS, STEEL, 3 INCHES THRU 12 INCHES, SD-000-000-L-630-210.	4	1

SPOOL NUMBERS

SP029-01 CW22-2A SP029-01 CW22-2B

PERMIT STAMP

# CONSTRUCTION WORK PACKAGE

**Project Name:**

**Project CWP WBS No:**

CWP	Plant	Area	Discipline	Sequence No
C	W	P	-	-

**Description:**

Rev. No	Rev Description	Date	Author	Checked By:			Approved By:	
				Contracts admin.	Project Controls	WFP Manager	Contractor	Construction/ Planning Manager
A	Issued For Review	MM/DD/YYYY						
B	IFC	MM/DD/YYYY						
C	Contractor Finalization	MM/DD/YYYY						

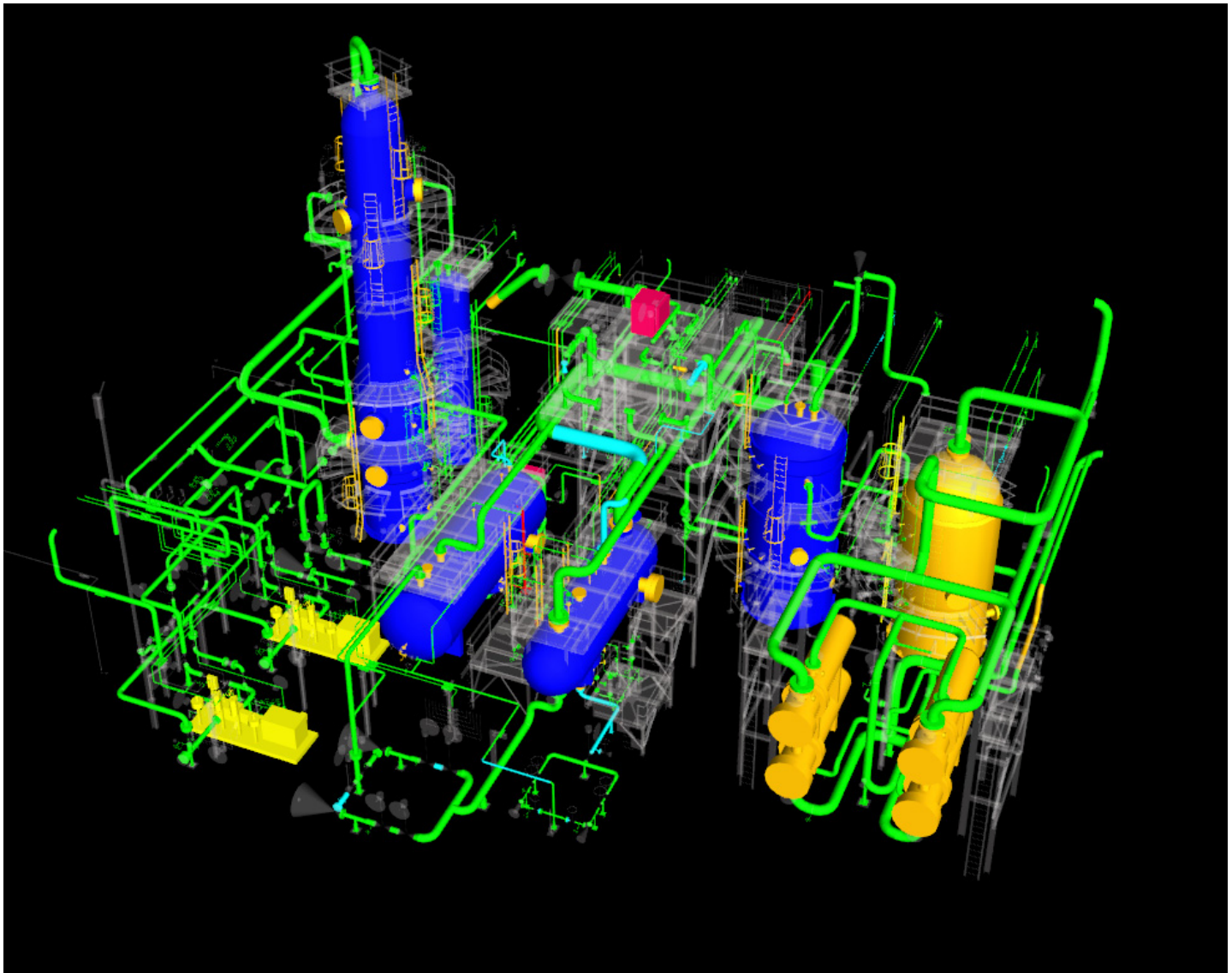

# CONSTRUCTION WORK PACKAGE

Project Name:

Project CWP WBS No:

# Company Logo

CWP

Plant

Area

Discipline

Sequence No

C W P - - - -

Description:

## Table Of Contents

Section No.	Section Description	# of Sheets
1.0	Scope of Work	
2.0	CWP Reference List	
3.0	Engineering Information	
4.0	Craft / Manpower	
5.0	Direct Field Equipment and Materials	
6.0	Safety	
7.0	Quality	
8.0	Regulatory Approvals and Permits	
9.0	Sub-contracts (Construction Contractor)	
10.0	Vendor Support	
11.0	Rigging Studies	
12.0	Scaffolding	
13.0	Special Equipment, tools and consumables	
14.0	Waste Management	
15.0	Risk Register	
16.0	WorkFace Planning	
17.0	Project Controls	
18.0	Turnover Documents	
19.0	3D Model Shots of CWP	
20.0	Submittals	
21.0	Contact List	

# CONSTRUCTION WORK PACKAGE

**Project Name:**

## Company Logo

**Project CWP WBS No:**

CWP	Plant	Area	Discipline	Sequence No
C W P -	-	-	-	-

**Description:**

## 1.0 SCOPE OF WORK

### 1.1 Summary Description of the Scope of Work

*A summary description of the scope of this CWP is to be provided here. Reference additional CWPs, Fabrication Work Plans and/or Modularization Work Plans that will be combined to form a construction or fabrication contract.*

### 1.2 Execution Strategy

*Provide the strategic intent or Path of Construction for scopes to be executed in this CWP. Reference integration and interface requirements and Project Schedule.*

### 1.3 Execution Milestones

*Identify key milestone dates for scopes of work referenced based on the Level III Project Schedule.*

### 1.4 Work Included

*Include any scope items that are not contained in the defined EWPs, or where the referenced documents do not adequately convey the scope.*

### 1.5 Work excluded

*Identify work that is specifically not included that is not identified in the defined EWPs, or where the referenced documents do not adequately convey the limits of scope.*

## 2.0 CWP REFERENCE LIST

### 2.1 CWP Reference List and Interface lists

*Identify additional CWPs that must be referenced to understand scope and execution strategy.*

*Identify Tie-in requirements document*

### 2.2 Owner Supplied Sub-Contractors

*Provide specific list of CWPs executed buy owner supplied sub-contractors pertinent to this CWP.*



# CONSTRUCTION WORK PACKAGE

Project Name:

## Company Logo

Project CWP WBS No:

CWP	Plant	Area	Discipline	Sequence No
C W P -	-	-	-	-

Description:

## 3.0 ENGINEERING INFORMATION

### 3.1 Engineering Work Package List

*A listing of all EWPs associated with this CWP including EWP number, description and revision*

### 3.2 Holds List

*Identify Hold and forecast release for documents listed but not released*

### 3.3 Additional Technical Information

*Identify any technical information that is not included in other documentation*

### 3.4 Technical document lists

*Identify and include the lists of technical documents included in this CWP*

## 4.0 MANPOWER

### 4.1 Manpower Requirement

*Provide an estimate of manpower requirements*

### 4.2 Density calculations

*Complete workplace density calculations*

### 4.3 Special Skills

*Identify all specialty skill requirements to complete tasks and their impact on schedule (if any)*

# CONSTRUCTION WORK PACKAGE

Project Name:

## Company Logo

Project CWP WBS No:

CWP	Plant	Area	Discipline	Sequence No
C W P -	-	-	-	-

Description:

## 5.0 MATERIALS

### 5.1 Bill of Materials Matrix (owner, engineer, vendor, contractor, fabricator supplied)

List responsibilities for materials not identified in EWPs. Ensure Cross-reference lists between tag numbers; requisition numbers, PO numbers, and IFC drawing numbers are included in EWPs.

### 5.2 Owner supplied equipment and materials

Must include all owners provided, or free-issued to Contractor, materials and tagged items.

### 5.3 Required at Site Dates (change to key and long lead)

Confirmation that material deliveries conform to Require at Site dates (RAS). Include RAS vs. ETA

### 5.4 Total Quantities

Provide Total material quantities as applicable (i.e. Ea, Tonne, Y cu, ft, dia-inch, etc.)

## 6.0 SAFETY

### 6.1 Safety

Provide high level Job Hazard Analysis for the identified work scopes, rank and set priorities for hazardous jobs contained in the execution of the CWP. These jobs should be the first priority for analysis and identification of items such as:

- Safe work plans
- Special Training requirements
- Special PPE requirements
- Special Permits (confined space, road closures, man baskets, lock-outs, etc)
- WHIMIS/MSDS requirements

Note: Detailed JHAs or FLHAs will take place at the IWP level. (To be provided by the Contractor)

# CONSTRUCTION WORK PACKAGE

Project Name:

## Company Logo

Project CWP WBS No:

CWP	Plant	Area	Discipline	Sequence No
C W P -	-	-	-	-

Description:

## 7.0 QUALITY

### 7.1 Inspection and Test Plans

All work defined in this CWP will be executed to requirements of Owner-approved Inspection and Test Plans (ITP). ITPs will be developed in compliance to Owner document XXX-XXX-000 Contractor Quality Requirements Specification Standard.

### 7.2 Weld Procedures

No welding process will be applied to the execution of scopes defined in this CWP without an approved Welding Procedure. Welding Procedures will satisfy welding requirements identified in EWP's listed in Section 2.0 EWP List.

### 7.3 Survey Requirements

This section should state the strategic intent for survey requirements and survey control plan for the scopes defined

## 8.0 REGULATORY APPROVALS AND PERMITS

### 8.1 Regulatory Approval Requirements

Regulatory Approval Requirements and compliance status must be communicated to contractors. Review compliance requirements and include applicable special permits required for execution of the CWP. (Such as Building Permits, Potable Water, Disposal, etc.)

### 8.2 Permit Schedule

A list of permit requirements for the defined scopes is to be provided.

# CONSTRUCTION WORK PACKAGE

Project Name:

## Company Logo

Project CWP WBS No:

CWP	Plant	Area	Discipline	Sequence No
C W P -	-	-	-	-

Description:

## 9.0 SUB-CONTRACTS (Construction Contractor)

### 9.1 Contractor activities

*Provide an explanation of the services to be sub-contracted as well as the target start and completion dates for said services and the contract formation process.*

### 9.2 Services Provided

*List the services that will be provided to the contractor by a sub-contractor, and by Owner, if they are to be different than agreed.*

## 10.0 VENDOR SUPPORT

### 10.1 Equipment List Vendor Requiring Support

*Provide a list of applicable equipment that will require vendor assistance.*

### 10.2 Purchase Order Schedule

*Provide confirmation that a Contract or Purchase Order is in place.*

### 10.3 Vendor Contact Information

*Prepare a list of Vendor contact information, notification requirements and anticipated required at site dates.*

# CONSTRUCTION WORK PACKAGE

Project Name:

## Company Logo

Project CWP WBS No:

CWP	Plant	Area	Discipline	Sequence No
C W P -	-	-	-	-

Description:

## 11.0 Critical Lifts / Crane Schedule

### 11.1 Lift Studies

*Include applicable anticipated critical lifts for the work scope in this CWP. (To be incorporated into the detailed IWPs)*

### 11.2 Lift Schedule

*Provide a lift schedule that links requirements to the Level 3 Project Schedule for this CWP.*

## 12.0 SCAFFOLDING

### 12.1 Scaffolding Plan

*Provide the estimated scaffolding types, location, duration and quantity requirements (including materials and labor) for the scope of work associated with the CWP.*

## 13.0 SPECIAL EQUIPMENT, TOOLS AND CONSUMABLES

### 13.1 Special Construction Equipment

*Provide a listing of special construction equipment needed and the availability timelines (if it is Owner supplied)*

### 13.2 Special Tools and Consumables

*Identify all special tools and consumable requirements necessary to perform the work (e.g. refractory dry-out, laser alignment, etc.)*

# CONSTRUCTION WORK PACKAGE

Project Name:

## Company Logo

Project CWP WBS No:

CWP	Plant	Area	Discipline	Sequence No
C W P -	-	-	-	-

Description:

## 14.0 WASTE MANAGEMENT

### 14.1 Waste Management Plan

*Typically the Waste Management Strategy/Plan is defined in general terms in the Construction Execution Plan with respect to responsibilities.*

*The Contractor is to provide a listing here as to the types and estimated quantities of waste associated with the CWP along with the discarding plan. (This to be in alignment with the overall Site Waste Management Plan)*

## 15.0 RISK REGISTER

### 15.1 Risk and Mitigation

*Provide a listing of items from the risk register that apply to the CWP complete with mitigation measures and an associated status report.*

# CONSTRUCTION WORK PACKAGE

Project Name:

## Company Logo

Project CWP WBS No:

CWP	Plant	Area	Discipline	Sequence No
C W P -	-	-	-	-

Description:

## 16.0 WORKFACE PLANNING

### 16.1 Installation Work Package List and Schedule

*A detailed breakdown of the planned number IWPs associated with the CWP is to be provided by the Contractor along with the release plan.*

The Contractor Shall follow the implementation practices as described but CII and COAA.

(Insert Links to Web information for COAA, CII, and the 272IR)

# CONSTRUCTION WORK PACKAGE

**Project Name:**

## Company Logo

**Project CWP WBS No:**

CWP	Plant	Area	Discipline	Sequence No
C W P -	-	-	-	-

**Description:**

## 17.0 PROJECT CONTROLS

### 17.1 Integrated Schedule

*A detailed Level 3 construction schedule showing integration; with other construction disciplines and contractors is to be provided by Owner's Project Controls group along with an overall narrative of the proposed Suncor Execution Strategy.*

### 17.2 Progress and Performance Measurement

*Provide a confirmation and listing of:*

- *progress measurement and performance requirements*
- *the support mechanisms are set up and;*
- *the material quantities and labour are rolled up to the required WBS level.*

*Add WBS chart to outline WBS numbers within this CWP*

## 18.0 TURNOVER DOCUMENTS

### 18.0 Turnover Document Matrix

*Provide a list or matrix of the required documents for Turnover that pertains to this CWP.*

### 18.1 Turn Over Responsibility

*Reference the Project Turnover Responsibility Matrix*

### 18.2 Templates for Turnover Binders

*Reference the location of the Templates required to develop the Turnover Binders.*



# CONSTRUCTION WORK PACKAGE

Project Name:

## Company Logo

Project CWP WBS No:

CWP		Plant		Area		Discipline		Sequence No
C	W	P	-	-	-			

Description:

## 19.0 3D Model Shots Of CWP

### 19.0 Model Shots

*Include here several 3D model shots of the CWP*

## 20.0 Submittals

### 20.0 Submittals

- *CONTRACTOR to submit to the OWNER an approved Methodology Statement (or equivalent) for this CWP two weeks prior to commencing work.*
- *CONTRACTOR to submit to the OWNER a schedule for this CWP based on IWPs two weeks prior to commencing work.*
- *CONTRACTOR to submit to the OWNER a resource staffing plan for this CWP two weeks prior to commencing work.*
- *CONTRACTOR to submit to the OWNER a detailed equipment plan (complete with pricing) for this CWP two weeks prior to commencing work.*
- *CONTRACTOR to submit to the OWNER an estimate of man hours (complete with pricing) for this CWP two weeks prior to commencing work.*
- *CONTRACTOR to submit to the OWNER a status listing of all CONTRACTOR supplied items (complete with pricing) required for this CWP two weeks prior to commencing work.*
- *CONTRACTOR to submit to the OWNER for approval the proposed ITP for this CWP two weeks prior to commencing work.*
- *CONTRACTOR to submit to the OWNER for approval a job hazard analysis for this CWP two weeks prior to commencing work.*
- *CONTRACTOR to submit to the OWNER for approval a rigging/lifting study for this CWP two weeks prior to commencing work.*
- *CONTRACTOR to submit to the OWNER the work permit(s) for this CWP two weeks prior to commencing work.*

# CONSTRUCTION WORK PACKAGE

Project Name:

## Company Logo

Project CWP WBS No:

CWP	Plant	Area	Discipline	Sequence No
C W P -	-	-	-	-

Description:

## 21.0 Contact List

### 20.0 Contact List

*Provide a comprehensive list of Contact Information for:*

- *Construction Management Personnel*
- *Project Personnel*
- *Engineering Personnel*
- *Materials Management*
- *Vendors*
- *Document Owners*
- *Area Hospitals and Doctors*
- *Emergency Response Teams*
- *Etc.,*

# ENGINEERING WORK PACKAGE

**Project Name:**

**Project WBS No:**

EWP	Plant	Area	Discipline	Sequence No
E W P	-	-	-	-

**Description:**

Rev. No	Rev Description	Date	Author	Checked By:			Approved By:	
				Contracts admin.	Project Controls	WFP Manager	Contractor	Construction/ Planning Manager
A	Issued For Review	MM/DD/YYYY						
B	IFC	MM/DD/YYYY						
C	Contractor Finalization	MM/DD/YYYY						

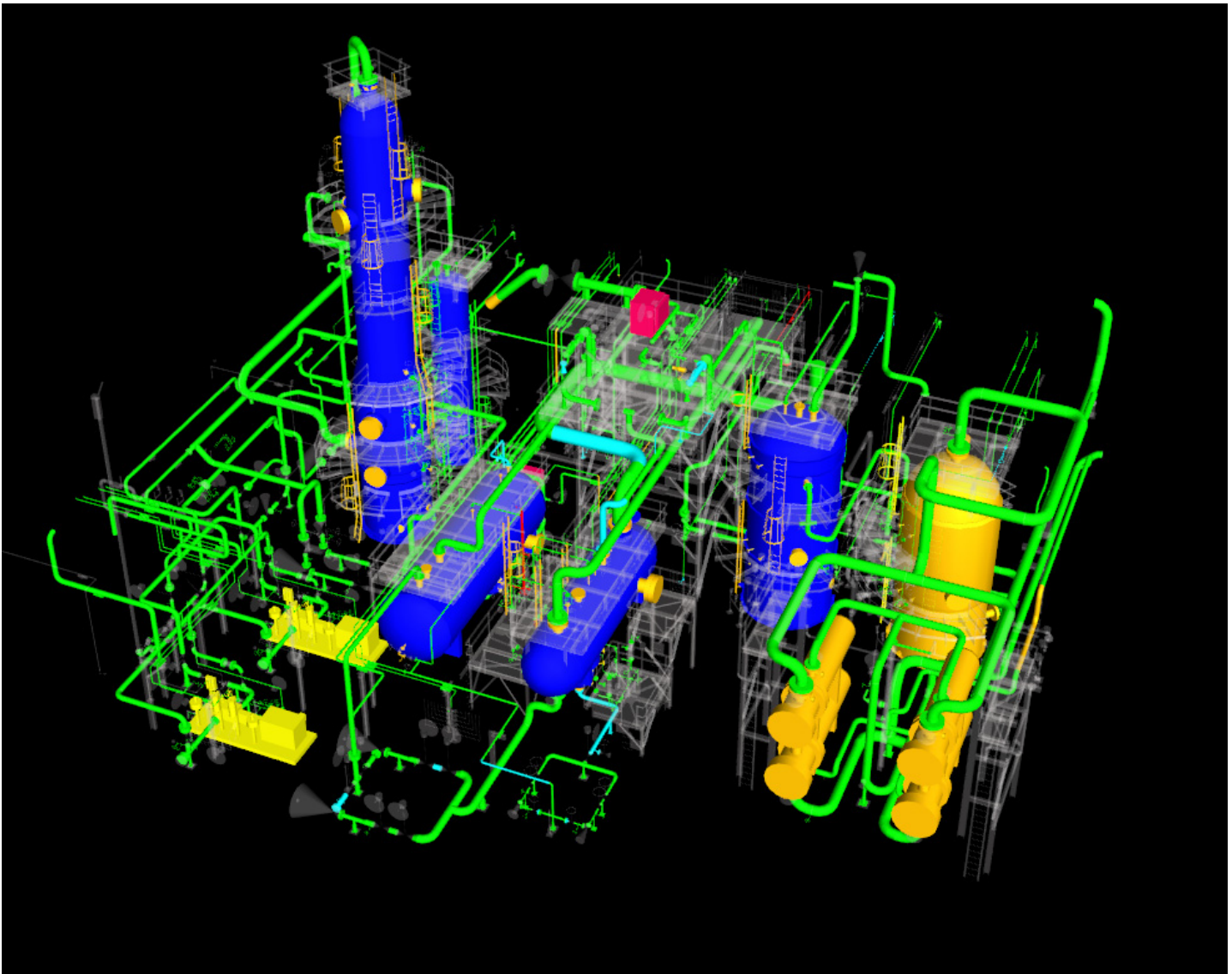

# ENGINEERING WORK PACKAGE

<b>Project Name:</b>									
<b>Project WBS No:</b>									
EWP		Plant		Area		Discipline		Sequence No	
E	W	P	-	-	-	-	-	-	
<b>Description:</b>									

Section No.	Section Description	# of Sheets
1.0	Scope of Work	
2.0	EWP Reference List	
3.0	Engineering Information	
4.0	Quality	
5.0	Vendor Support	
6.0	WorkFace Planning	
7.0	3D Model Shots of EWP	
8.0	Contact List	

## 1.0 SCOPE OF WORK

# ENGINEERING WORK PACKAGE

Project Name:

Project WBS No:

EWP	Plant	Area	Discipline	Sequence No
E W P -	-	-	-	-
Description:				

## 1.1 Summary Description of the Scope of Work

A summary description of the scope of this EWP is to be provided here. Reference additional EWPs.

## 1.2 Execution Strategy

Provide the strategic intent or Path of Construction for scopes to be executed in this EWP. Reference integration and interface requirements and Project Schedule.

## 1.3 Execution Milestones

Identify key milestone dates for scopes of work referenced based on the Level III Project Schedule.

## 1.4 Work Included

Include any scope items that are not contained in the defined EWPs, or where the referenced documents do not adequately convey the scope.

## 1.5 Work excluded

Identify work that is specifically not included that is not identified in the defined EWPs, or where the referenced documents do not adequately convey the limits of scope.

## 2.0 EWP REFERENCE LIST

### 2.1 EWP Reference List

Identify additional EWPs that must be referenced to understand scope and execution strategy.

# ENGINEERING WORK PACKAGE

Project Name:

Project WBS No:

EWP	Plant	Area	Discipline	Sequence No
E W P -	-	-	-	-
Description:				

## 3.0 ENGINEERING INFORMATION

### 3.1 Holds List

*Identify Hold and forecast release for documents listed but not released*

### 3.2 Additional Technical Information

*Identify any technical information that is not included in other documentation*

### 3.3 Technical document lists

*Identify and include the lists of technical documents included in this EWP*

## 4.0 QUALITY

### 4.1 Inspection and Test Plans

*All work defined in this EWP will be executed to requirements of Owner-approved Inspection and Test Plans (ITP). ITPs will be developed in compliance to Owner document XXX-XXX-000 Contractor Quality Requirements Specification Standard.*

### 4.2 Weld Procedures

*No welding process will be applied to the execution of scopes defined in this EWP without an approved Welding Procedure. Welding Procedures will satisfy welding requirements identified in EWPs listed in Section 2.0 EWP List.*

# ENGINEERING WORK PACKAGE

Project Name:

Project WBS No:

EWP	Plant	Area	Discipline	Sequence No
E W P -	-	-	-	-
Description:				

## 5.0 VENDOR SUPPORT

### 5.1 Equipment List Vendor Requiring Support

*Provide a list of applicable equipment that will require vendor assistance.*

### 5.2 Purchase Order Schedule

*Provide confirmation that a Contract or Purchase Order is in place.*

### 5.3 Vendor Contact Information

*Prepare a list of Vendor contact information, notification requirements and anticipated required at site dates.*

# ENGINEERING WORK PACKAGE

Project Name:

Project WBS No:

EWP	Plant	Area	Discipline	Sequence No
E W P -	-	-	-	-

Description:

## 6.0 WORKFACE PLANNING

### 6.1 Field Installation Work Package List and Schedule

*A detailed breakdown of the planned number IWPs associated with the EWP is to be provided by the Contractor along with the release plan.*

The Contractor Shall follow the implementation practices as described but CII and COAA.

(Insert Links to Web information for COAA, CII, and the 272IR)



# ENGINEERING WORK PACKAGE

Project Name:

Project WBS No:

EWP	Plant	Area	Discipline	Sequence No
E W P -	-	-	-	-

Description:

## 7.0 3D Model Shots Of EWP

### 7.0 Model Shots

*Include here several 3D model shots of the EWP*

## 8.0 Contact List

### 8.0 Contact List

*Provide a comprehensive list of Contact Information for:*

- *Project Personnel*
- *Engineering Personnel*
- *Materials Management*
- *Vendors*
- *Document Owners*

## IWP ELECTRICAL

PROJECT INFORMATION				
Project Number	IWP Number & Revision Number	All Related CWP & Revision Number	Area/System/Subsystem/Discipline	Work Performed by
1000	IWP 8120-051	CWP 8120-01	Area 8120 - Electrical	

AUTHORSHIP AND APPROVALS		
<b>Prepared by</b>		01 NOV 07
<b>Revised By</b>		01 NOV 07
<b>Issued by</b>		01 NOV 07
<b>Released by</b>		
<b>Assigned by</b>		
<b>Reason to Recall</b>		
<b>Completed by</b>		

## Scope

Install 300 meters of 60cm, 200 meters of 30cm and 300 meters of 10 cm cable tray with down comers, all complete with structural steel supports within Compressor Building 8120-BG-001. See Drawing #8120-65N-042 for lay out, elevation and details.

## Deliverable

800 meters of cable tray ready for wire pull commencing 15 May 2006. Activities

## Activities

- The welding crew shall install, 25 type CTS 60T, 20 type CTS 60A, 30 type CTS 30T, 12 type CTS 60, 6 type CTS 30, 100 type CTS 10 cable tray supports welded to the building structural steel. 80 hours each for structural steel welder and helper/fitter.
- The Electrical crew shall bolt the cable tray to the supports 60 cm, 30 cm, 10 cm cable tray with bends and tees as indicated on drawing #8120-65N-042 and standards drawing #8000-65-002. 80 hours for a four-man crew (an Electrician with 2 – apprentice and one helper).

## Resources

## Equipment

- Portable mobile welding machine and man lift for welding crew.
- 2 man lifts and steel cutting mitre saw

## Tools

General hand tools for Welder and Electrician.

## Materials

- 25 – type CTS 60T cable tray support
- 20 – type CTS 60A cable tray support
- 30 – type CTS 30T cable tray support
- 12 – type CTS 60 cable tray support
- 6 – type CTS 30 cable tray support
- 100 – type CTS 10 cable tray support
- 300 meters Standard 60cm cable tray
- 200 meters Standard 30cm cable tray.
- 300 meters Light Weight 10cm cable tray
- 2 – cable tray 90 elbow type 2 60 cm
- 2 – cable tray 90 elbow type 3 60 cm
- 3 - cable tray tee type 4 60 cm
- 5 - cable tray end caps type 2 60 cm
- 4 – cable tray 90 elbow type 2 30 cm
- 4 – cable tray 90 elbow type 3 30 cm
- 2 – cable tray tee type 4 30 cm
- 45 - cable tray coupling 60 cm type L2 with nuts and bolts
- 30 – cable tray coupling 30 cm type L2 with nuts and bolts
- 50 – cable tray coupling 10 cm type 1 with nuts and bolts
- 100 - cable tray bonding clamps complete type 5

## Labour

- Structural Steel Welder.
- Fitter/Helper
- Electrician
- 2 - Apprentice
- 1 – Helper

## Work Instructions

Other trades shall be working in the Compressor building during the installation of the Cable Tray and supports. As the welder and electrical crews will be working most of the time from a

man lift, care must be taken of falling materials and tools on fellow workers below. Areas should be ribboned off to restrict access.

## Safety Equipment

- Training required for use of man-lift for complete crew.
- Safety Harness training for all members of the crew.

## Drawings

- Building general arrangement #8120-BG-001
- Cable Tray routing #8120-65N-042
- Cable tray installation standards #8000-65-002

## Vendor Information

- XYZ Speciality company supplier of CTFS wonder fastener.
- Vendor drawing number: 100-elec-8120-4

## Special Conditions

Special cable tray fastening system (CTFS) required due to operations request.

## Quality Control

Ensure that team installing the CTFS has vendor supplied installation details.

## Interdependencies

The building structural steel and large bore pipe shall be installed before welder's mobilized. Welder to start east wall, north end working south around the building, Electrical trades to

start approximately three days after welder crew has started and completed the supports for the east wall as a minimum.

## **Risk Planning**

## **Reverse Punch List (Error Proofing)**

## **Lessons Learned**

The CTFS system requested by operations was easy to install and saved approximately 20 minutes per connection.

## IWP PIPING

PROJECT INFORMATION				
Project Number	IWP Number & Revision Number	All Related CWP & Revision Number	Area/System/ Subsystem/ Discipline	Work Performed by
2111	IWP 2111-121	CWP 2111-01	Area 2111 - Piping	

AUTHORSHIP AND APPROVALS		
<b>Prepared by</b>		01 NOV 07
<b>Revised By</b>		01 NOV 07
<b>Issued by</b>		01 NOV 07
<b>Released by</b>		
<b>Assigned by</b>		
<b>Reason to Recall</b>		
<b>Completed by</b>		

## Scope

Install, fit and weld 24" carbon steel large bore piping from pump P-5304 discharge flange to Vessel C2112 inlet flange. The tower is 60' tall and the inlet flange is located at the top of the tower with a service platform 2' below. The pump is located 50' SE to the tower, the piping is elevated to 12 feet above grade and running west and north to south side of the tower and up to the nozzle.

The piping is fabricated into 3 spools A, B & C and requires 2 field welds after installation. The piping has two free standing pipe supports at grade and 2 located on the side of the tower.

Estimate spool length spool "A" is 50' long, spool "B" is 30' and spool "C" is 40' plus.

See DWG# \_\_\_\_\_ & ISO \_\_\_\_\_.

## Deliverable

- Pipe supports materials, pipe spools, gaskets and hardware material for work commencing on Oct 10-12.
- -Required an 80-ton crane for spool erection and a 30 ton for tailing and pipe support installation.
- -Scaffold must be in place prior to work commencing.

## Activities

### Sequence of spools installation from tower to pump

- Surveyors to verify centerline and elevation on pipe support foundations.
- Erect scaffolds at pipe support and field joints for access. Leave temporary access for spool installation.
- Piping crew to verify piping materials, gasket and hardware, spool dimensions, check for shipping damage, and prepare for installation.
- Transport material and spools from lay down yard to installation site.
- Install pipe supports, once installed surveyor to verify elevation



- Setup 80t crane east of tower and lay spool north of crane running east/west with tower connection on west side. And setup tailing 30t crane on tail end of spool.
- Prepare rigging material, verify sling sizes and length, check for damage.
- Lift and install spool "A" from tower inlet flange down using an 80 ton for the main lift and 30t for tailing. Secure spool with two tower supports.
- Install spool "B" on pipe support and temporary fit and secure to spool "A".
- Install spool "C" temporary bolt to pump discharge flange and secure to pipe support.
- Review attached welding procedure and verify welding rods.
- Align pipe flange to pump discharge, fit and weld two joints with QC inspection and approval of welding.
- NDE joints.
- Bolt up crew to check bolt tension on flanges and pipe support.
- Dismantle scaffolds.
- Daily progress report.

Next step is hydro piping and EHT and insulation

## Resources

## Equipment

- 80T mobile crane for spool installation and a 30t for tailing and install pipe supports.
- One Rectifier welding machine; rod oven.
- One set of Surveyor equipment.

## Tools

- Rigging wire slings and shackles,
- Oxy/Acct. cutting outfit, welding lead; hand grinders; rasp file; 1 7/8" combination wrenches, 1 7/8" torque wrench and pipe fitter hand tools.

## Materials

- Pipe support materials and 3 spools at lay down yard.
- Hardware and gaskets are bagged and tagged at warehouse.
- Welding rods are in tool crib in welding rod's oven.
- Scaffolding material.

## Labour

- 1 – Scaffold F/M 3 Scaffolders and 1 labour.
- 1 – Piping foreman; 3 p/f riggers, 1 fitter, 1B-pressure welders and 1 apprentice.

## Work Instructions

- All crane operators must have project certification. Welders must be tested on site.
- Setup red flagging and clear rigging area; complete SPA before work proceeds.
- Setup welding hoarding or screens and sparks containment and covers up equipment below.
- Maintain a fire watch when welding and cutting.
- Coordinate with other craft and Forman working around the same area.

## Safety Equipment

- Barricade tape; fire extinguishers; safety harness; respirators and smoke removal.

## Drawings

- Piping Isometric
  - 53-LP-2110-CS-111 sheet 1 Rev 3
  - 53-LP-2110-CS-111 sheet 2 Rev 3
- Spool Drawing
  - 53-LP -0211-CS- A
  - 53-LP -0211-CS- B

- 53-LP -0211-CS- C

## Vendor Information

Piping fabricator to provide piping cut sheets & inform of any RFIs, changes or materials are outstanding.

## Special Conditions

We will be working at heights for a lot of this IWP so take time in the morning and after lunch to reinforce 'working at heights' safety standard. Exercise and stretch in the morning before climbing the tower. Apprentice must be teamed with a journeyman.

## Quality Control

- All bolts are to be torque to project spec 2111-ST-S2 rev 1. Spec is attached.
- Welding inspector to check on welder periodically and verify correct welding rods.
- Notify Willy Engineer for a spot check on bolt tensioning.

## Interdependencies

This work package is dependent on the availability an 80T cranes which are currently being used by Ironworker installing structural steel. One week prior to start of work confirm the availability of the crane.

## Risk Planning

- Do a hazard analysis before rigging spool to connect to top of tower.
- Conduct pre lift meeting with crew directly prior to lift occurring.

## Reverse Punch List (Error Proofing)

- We have recently experienced some quality issues. Wrong gasket material was delivered to site for installation at pump's discharge flange.
- Have experienced fitter verify the gasket material against drawing's material list before installation and inform Forman Dale if any discrepancies.

## Lessons Learned

Warehouse personnel must verify all material before delivery to site for installation.

## IWP STRUCTURAL STEEL

PROJECT INFORMATION				
Project Number	IWP Number & Revision Number	All Related CWP & Revision Number	Area/System/Subsystem/Discipline	Work Performed by
1000	IWP 8120-121	CWP 8120-2	Area 8120 - Structural	

AUTHORSHIP AND APPROVALS		
<b>Prepared by</b>		01 NOV 07
<b>Revised By</b>		01 NOV 07
<b>Issued by</b>		01 NOV 07
<b>Released by</b>		
<b>Assigned by</b>		
<b>Reason to Recall</b>		
<b>Completed by</b>		

## Scope

Install bridge crane steel in the Compressor Shelter and access stairway from the Compressor Shelter to the east/west pipe rack. The Compressor Shelter is located in the NE corner of Area 8120. The bridge crane steel runs the entire length of the Compressor Shelter along the north and south walls at approximately elevation 85'. The stairway is at the west end of the Compressor Shelter and runs plant north to the top of the pipe rack. The stairway starts at elevation 85' and goes to elevation 102' at the top of the pipe rack. The platform at elevation 85' is approximately 31' feet above the existing grade with clear access from the west side of the Compressor Shelter.

## Deliverable

- Completed installation of the bridge crane steel in preparation of the bridge crane arrival on 15 Oct 12.
- Complete the stairway installation to allow the ongoing pipe and electrical installation at elevation 102' of the east/west pipe rack.

## Activities

This work represents two (2) weeks of work for the crew.

The structural steel crew will shake out the steel for the described work and stage the materials for delivery to the west end of the Compressor Shelter. This will take two days. The erection team will commence installing approximately 15 tons of bridge crane steel starting at the east end north side then moving to the south side. This will be time consuming work due to the congestion and amount of work that will be performed from manbaskets.

The bolt up crew will start the preassembly of the stair stringers and treads along with the landing platforms at ground level on the west end of the Compressor Shelter. All handrails and grating will be installed at grade.

The bolt up crew will move to the north side bridge crane steel once the erection crew moves to the south side. We will have to watch the movement of the manlifts so as not to interfere with the two work activities on either side of the shelter.

Once erection is complete in the Compressor Shelter the erection team will move on to the installation of the stairway and landing platforms.

A reminder that the sheeting contractor will be working on the outside of the north and south walls while we are doing our erection on the inside.

## Resources

### Equipment (See Construction Equipment Schedule for details)

- 3990T Crane
- 65T Mobile
- 2 – 80 foot manlift
- 3 – flatbed trailers(part time)
- air compressor
- 2 – welding machines
- 4 – 50 retractable connectors
- 4 – 50 retractable connectors

## Tools

- 3 – impact guns
- 1 – mag drill
- 2 – 20' extension ladders
- 200' welding lead
- hammer wrenches – 1 ¼ " and 1 5/8"
- selection of wire slings and shackles

## Materials

- All steel is available in the steel laydown yard reference grid 12B.
- Bolts and nuts; 3X3 shims; grating clips; bridge crane rail hold down brackets; all these items are at the warehouse bagged and tagged reference location row 2 shelf B3.

- 1/2" inch wire rope and Crosby clips

## Labour

- 1 – working foreman;
- 4 – journeyman IW;
- 2 – apprentice;
- 2 – helpers;
- 2 - operators

## Work Instructions

- All manlift operators must have project certification.
- Several pieces of equipment are installed at the east end of the building and must be protected from weld splatter and falling tools. Use scaffolding frames with 5/8 inch plywood and fire blanket to cover the equipment.
- Red flag the selected areas of overhead work.
- Work closely with Jim Siding, foreman for GOOD Enclosures INC, working on the outside of the north wall of the Shelter.

## Safety Equipment

Barricade tape; fire extinguishers; safety harness; and lanyards.

## Drawings

- Compressor Shelter - Isometric View Dwg 8120-stru-112 rev 3;
- Framing Sheets Dwg 8120-stru-113 rev 2 Sheets 1 to 5
- Elevations Dwg 8120-stru-110 rev 2 Sheets 1 to 4
- Stair Sections Dwg 8120-stru-114 rev 1
- Sections & Details Dwg 8120-stru-115 rev 2 Sheets 1 to 3



## Vendor Information

Big Steel Fabricators (BFS) have included all erection drawings with appropriate piece Sepks. They have supplied nuts and bolts with a 10% bump. A set of erection drawings are attached and the nuts and bolts are bagged and tagged in Bin 72/ Row 6 at the main warehouse.

## Special Conditions

- We will be working at heights for a lot of this IWP so take time in the morning and after lunch to reinforce 'working at heights' safety standard.
- Permit required when access to Compressor Shelter is blocked during setting of crane rails.
- The 2 – apprentice have just recently joined the project so they must be teamed with a journeyman while working at heights.

## Quality Control

- All bolts are to be tortured per the project spec 8120-stru-S2 rev 1. Specs including weld procedures are attached.
- Notify Wil Engineer for a spot check on bolt tensioning. CYY Crane Company will inspect all crane rail supports prior to rail installation.

## Interdependencies

This work package is dependent on the availability of 2 – 80' manlifts which are currently being used by electricians running cable tray. One week prior to start of work confirm the availability on the equipment and order short term rental if electrical work is not complete.

## Risk Planning

At this time, there is no known risk that would prevent the work package from proceeding.

## Reverse Punch List (Error Proofing)

- We have recently experienced some quality issues related to bolt tensioning. After each bolt is tensioned the nut will be Sepked with a yellow Sepk to indicate the work is complete.
- We have also had some issues with the BFS's piece Sepks not matching the deliver inventory. Our experience has shown that the piece Sepk on the steel is correct and matches the erection drawing. If this occurs notify Jim Bob Receiver at the warehouse.

## Lessons Learned

To be added at completion of the job. Team meeting to be held with Ron Planner to capture the LL.

## List of Attachments

1. Three Week Area Schedule
2. Construction Equipment Schedule
3. Material Report
4. Weld Procedures
5. Specs
6. Access/Egress Permit
7. Quantity and Unit Rate Report

# CONSTRUCTION WORK PACKAGE

**Project Name:**

**Project CWP WBS No:**

CWP	Plant	Area	Discipline	Sequence No
C	W	P	-	-

**Description:**

Rev. No	Rev Description	Date	Author	Checked By:			Approved By:	
				Contracts admin.	Project Controls	WFP Manager	Contractor	Construction/ Planning Manager
A	Issued For Review	MM/DD/YYYY						
B	IFC	MM/DD/YYYY						
C	Contractor Finalization	MM/DD/YYYY						

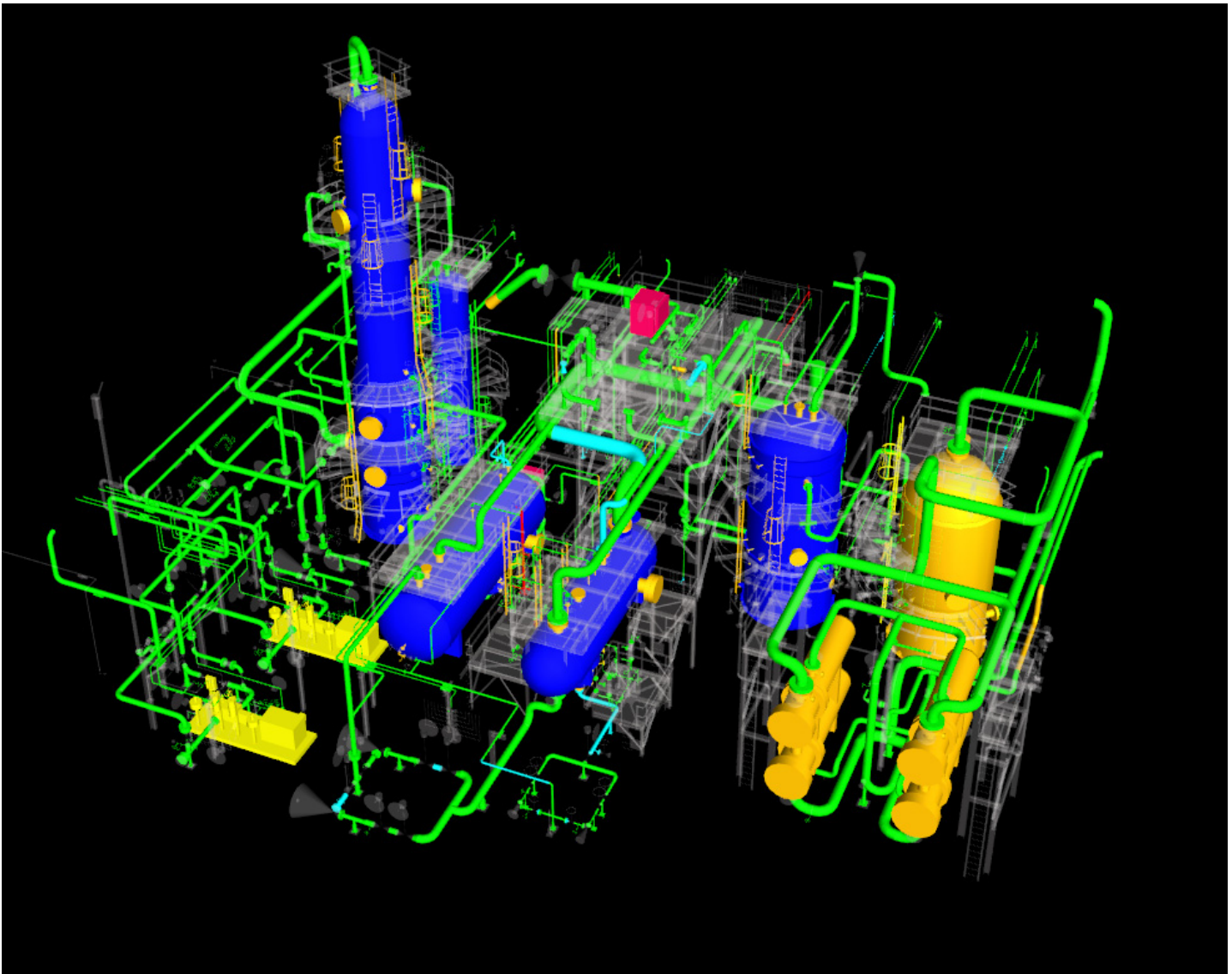

# CONSTRUCTION WORK PACKAGE

<b>Project Name:</b>				<b>Company Logo</b>			
<b>Project CWP WBS No:</b>							
CWP		Plant		Area		Discipline	Sequence No
C	W	P	-	-	-	-	-
<b>Description:</b>							

## Table Of Contents

Section No.	Section Description	# of Sheets
1.0	Scope of Work	
2.0	CWP Reference List	
3.0	Engineering Information	
4.0	Craft / Manpower	
5.0	Direct Field Equipment and Materials	
6.0	Safety	
7.0	Quality	
8.0	Regulatory Approvals and Permits	
9.0	Sub-contracts (Construction Contractor)	
10.0	Vendor Support	
11.0	Rigging Studies	
12.0	Scaffolding	
13.0	Special Equipment, tools and consumables	
14.0	Waste Management	
15.0	Risk Register	
16.0	WorkFace Planning	
17.0	Project Controls	
18.0	Turnover Documents	
19.0	3D Model Shots of CWP	
20.0	Submittals	
21.0	Contact List	

# CONSTRUCTION WORK PACKAGE

**Project Name:**

## Company Logo

**Project CWP WBS No:**

CWP	Plant	Area	Discipline	Sequence No
C W P -	-	-	-	-

**Description:**

## 1.0 SCOPE OF WORK

### 1.1 Summary Description of the Scope of Work

*A summary description of the scope of this CWP is to be provided here. Reference additional CWPs, Fabrication Work Plans and/or Modularization Work Plans that will be combined to form a construction or fabrication contract.*

### 1.2 Execution Strategy

*Provide the strategic intent or Path of Construction for scopes to be executed in this CWP. Reference integration and interface requirements and Project Schedule.*

### 1.3 Execution Milestones

*Identify key milestone dates for scopes of work referenced based on the Level III Project Schedule.*

### 1.4 Work Included

*Include any scope items that are not contained in the defined EWPs, or where the referenced documents do not adequately convey the scope.*

### 1.5 Work excluded

*Identify work that is specifically not included that is not identified in the defined EWPs, or where the referenced documents do not adequately convey the limits of scope.*

## 2.0 CWP REFERENCE LIST

### 2.1 CWP Reference List and Interface lists

*Identify additional CWPs that must be referenced to understand scope and execution strategy.*

*Identify Tie-in requirements document*

### 2.2 Owner Supplied Sub-Contractors

*Provide specific list of CWPs executed buy owner supplied sub-contractors pertinent to this CWP.*

# CONSTRUCTION WORK PACKAGE

Project Name:

## Company Logo

Project CWP WBS No:

CWP	Plant	Area	Discipline	Sequence No
C W P -	-	-	-	-

Description:

## 3.0 ENGINEERING INFORMATION

### 3.1 Engineering Work Package List

*A listing of all EWPs associated with this CWP including EWP number, description and revision*

### 3.2 Holds List

*Identify Hold and forecast release for documents listed but not released*

### 3.3 Additional Technical Information

*Identify any technical information that is not included in other documentation*

### 3.4 Technical document lists

*Identify and include the lists of technical documents included in this CWP*

## 4.0 MANPOWER

### 4.1 Manpower Requirement

*Provide an estimate of manpower requirements*

### 4.2 Density calculations

*Complete workplace density calculations*

### 4.3 Special Skills

*Identify all specialty skill requirements to complete tasks and their impact on schedule (if any)*

# CONSTRUCTION WORK PACKAGE

Project Name:

## Company Logo

Project CWP WBS No:

CWP	Plant	Area	Discipline	Sequence No
C W P -	-	-	-	-

Description:

## 5.0 MATERIALS

### 5.1 Bill of Materials Matrix (owner, engineer, vendor, contractor, fabricator supplied)

List responsibilities for materials not identified in EWPs. Ensure Cross-reference lists between tag numbers; requisition numbers, PO numbers, and IFC drawing numbers are included in EWPs.

### 5.2 Owner supplied equipment and materials

Must include all owners provided, or free-issued to Contractor, materials and tagged items.

### 5.3 Required at Site Dates (change to key and long lead)

Confirmation that material deliveries conform to Require at Site dates (RAS). Include RAS vs. ETA

### 5.4 Total Quantities

Provide Total material quantities as applicable (i.e. Ea, Tonne, Y cu, ft, dia-inch, etc.)

## 6.0 SAFETY

### 6.1 Safety

Provide high level Job Hazard Analysis for the identified work scopes, rank and set priorities for hazardous jobs contained in the execution of the CWP. These jobs should be the first priority for analysis and identification of items such as:

- Safe work plans
- Special Training requirements
- Special PPE requirements
- Special Permits (confined space, road closures, man baskets, lock-outs, etc)
- WHIMIS/MSDS requirements

Note: Detailed JHAs or FLHAs will take place at the IWP level. (To be provided by the Contractor)

# CONSTRUCTION WORK PACKAGE

Project Name:

## Company Logo

Project CWP WBS No:

CWP	Plant	Area	Discipline	Sequence No
C W P -	-	-	-	-

Description:

## 7.0 QUALITY

### 7.1 Inspection and Test Plans

All work defined in this CWP will be executed to requirements of Owner-approved Inspection and Test Plans (ITP). ITPs will be developed in compliance to Owner document XXX-XXX-000 Contractor Quality Requirements Specification Standard.

### 7.2 Weld Procedures

No welding process will be applied to the execution of scopes defined in this CWP without an approved Welding Procedure. Welding Procedures will satisfy welding requirements identified in EWP's listed in Section 2.0 EWP List.

### 7.3 Survey Requirements

This section should state the strategic intent for survey requirements and survey control plan for the scopes defined

## 8.0 REGULATORY APPROVALS AND PERMITS

### 8.1 Regulatory Approval Requirements

Regulatory Approval Requirements and compliance status must be communicated to contractors. Review compliance requirements and include applicable special permits required for execution of the CWP. (Such as Building Permits, Potable Water, Disposal, etc.)

### 8.2 Permit Schedule

A list of permit requirements for the defined scopes is to be provided.



# CONSTRUCTION WORK PACKAGE

Project Name:

## Company Logo

Project CWP WBS No:

CWP	Plant	Area	Discipline	Sequence No
C W P -	-	-	-	-

Description:

## 9.0 SUB-CONTRACTS (Construction Contractor)

### 9.1 Contractor activities

*Provide an explanation of the services to be sub-contracted as well as the target start and completion dates for said services and the contract formation process.*

### 9.2 Services Provided

*List the services that will be provided to the contractor by a sub-contractor, and by Owner, if they are to be different than agreed.*

## 10.0 VENDOR SUPPORT

### 10.1 Equipment List Vendor Requiring Support

*Provide a list of applicable equipment that will require vendor assistance.*

### 10.2 Purchase Order Schedule

*Provide confirmation that a Contract or Purchase Order is in place.*

### 10.3 Vendor Contact Information

*Prepare a list of Vendor contact information, notification requirements and anticipated required at site dates.*

# CONSTRUCTION WORK PACKAGE

Project Name:

## Company Logo

Project CWP WBS No:

CWP	Plant	Area	Discipline	Sequence No
C W P -	-	-	-	-

Description:

## 11.0 Critical Lifts / Crane Schedule

### 11.1 Lift Studies

*Include applicable anticipated critical lifts for the work scope in this CWP. (To be incorporated into the detailed IWPs)*

### 11.2 Lift Schedule

*Provide a lift schedule that links requirements to the Level 3 Project Schedule for this CWP.*

## 12.0 SCAFFOLDING

### 12.1 Scaffolding Plan

*Provide the estimated scaffolding types, location, duration and quantity requirements (including materials and labor) for the scope of work associated with the CWP.*

## 13.0 SPECIAL EQUIPMENT, TOOLS AND CONSUMABLES

### 13.1 Special Construction Equipment

*Provide a listing of special construction equipment needed and the availability timelines (if it is Owner supplied)*

### 13.2 Special Tools and Consumables

*Identify all special tools and consumable requirements necessary to perform the work (e.g. refractory dry-out, laser alignment, etc.)*

# CONSTRUCTION WORK PACKAGE

Project Name:

## Company Logo

Project CWP WBS No:

CWP	Plant	Area	Discipline	Sequence No
C W P -	-	-	-	-

Description:

## 14.0 WASTE MANAGEMENT

### 14.1 Waste Management Plan

*Typically the Waste Management Strategy/Plan is defined in general terms in the Construction Execution Plan with respect to responsibilities.*

*The Contractor is to provide a listing here as to the types and estimated quantities of waste associated with the CWP along with the discarding plan. (This to be in alignment with the overall Site Waste Management Plan)*

## 15.0 RISK REGISTER

### 15.1 Risk and Mitigation

*Provide a listing of items from the risk register that apply to the CWP complete with mitigation measures and an associated status report.*

# CONSTRUCTION WORK PACKAGE

Project Name:

## Company Logo

Project CWP WBS No:

CWP	Plant	Area	Discipline	Sequence No
C W P -	-	-	-	-

Description:

## 16.0 WORKFACE PLANNING

### 16.1 Installation Work Package List and Schedule

*A detailed breakdown of the planned number IWPs associated with the CWP is to be provided by the Contractor along with the release plan.*

The Contractor Shall follow the implementation practices as described but CII and COAA.

(Insert Links to Web information for COAA, CII, and the 272IR)

# CONSTRUCTION WORK PACKAGE

**Project Name:**

## Company Logo

**Project CWP WBS No:**

CWP	Plant	Area	Discipline	Sequence No
C W P -	-	-	-	-

**Description:**

## 17.0 PROJECT CONTROLS

### 17.1 Integrated Schedule

*A detailed Level 3 construction schedule showing integration; with other construction disciplines and contractors is to be provided by Owner's Project Controls group along with an overall narrative of the proposed Suncor Execution Strategy.*

### 17.2 Progress and Performance Measurement

*Provide a confirmation and listing of:*

- *progress measurement and performance requirements*
- *the support mechanisms are set up and;*
- *the material quantities and labour are rolled up to the required WBS level.*

*Add WBS chart to outline WBS numbers within this CWP*

## 18.0 TURNOVER DOCUMENTS

### 18.0 Turnover Document Matrix

*Provide a list or matrix of the required documents for Turnover that pertains to this CWP.*

### 18.1 Turn Over Responsibility

*Reference the Project Turnover Responsibility Matrix*

### 18.2 Templates for Turnover Binders

*Reference the location of the Templates required to develop the Turnover Binders.*

# CONSTRUCTION WORK PACKAGE

Project Name:

## Company Logo

Project CWP WBS No:

CWP	Plant	Area	Discipline	Sequence No
C W P -				

Description:

## 19.0 3D Model Shots Of CWP

### 19.0 Model Shots

*Include here several 3D model shots of the CWP*

## 20.0 Submittals

### 20.0 Submittals

- *CONTRACTOR to submit to the OWNER an approved Methodology Statement (or equivalent) for this CWP two weeks prior to commencing work.*
- *CONTRACTOR to submit to the OWNER a schedule for this CWP based on IWPs two weeks prior to commencing work.*
- *CONTRACTOR to submit to the OWNER a resource staffing plan for this CWP two weeks prior to commencing work.*
- *CONTRACTOR to submit to the OWNER a detailed equipment plan (complete with pricing) for this CWP two weeks prior to commencing work.*
- *CONTRACTOR to submit to the OWNER an estimate of man hours (complete with pricing) for this CWP two weeks prior to commencing work.*
- *CONTRACTOR to submit to the OWNER a status listing of all CONTRACTOR supplied items (complete with pricing) required for this CWP two weeks prior to commencing work.*
- *CONTRACTOR to submit to the OWNER for approval the proposed ITP for this CWP two weeks prior to commencing work.*
- *CONTRACTOR to submit to the OWNER for approval a job hazard analysis for this CWP two weeks prior to commencing work.*
- *CONTRACTOR to submit to the OWNER for approval a rigging/lifting study for this CWP two weeks prior to commencing work.*
- *CONTRACTOR to submit to the OWNER the work permit(s) for this CWP two weeks prior to commencing work.*

# CONSTRUCTION WORK PACKAGE

Project Name:

## Company Logo

Project CWP WBS No:

CWP	Plant	Area	Discipline	Sequence No
C W P -	-	-	-	-

Description:

## 21.0 Contact List

### 20.0 Contact List

*Provide a comprehensive list of Contact Information for:*

- *Construction Management Personnel*
- *Project Personnel*
- *Engineering Personnel*
- *Materials Management*
- *Vendors*
- *Document Owners*
- *Area Hospitals and Doctors*
- *Emergency Response Teams*
- *Etc.,*

# ENGINEERING WORK PACKAGE

Project Name:

Project WBS No:

EWP	Plant	Area	Discipline	Sequence No
E W P	-	-	-	-

Description:

Rev. No	Rev Description	Date	Author	Checked By:			Approved By:	
				Contracts admin.	Project Controls	WFP Manager	Contractor	Construction/ Planning Manager
A	Issued For Review	MM/DD/YYYY						
B	IFC	MM/DD/YYYY						
C	Contractor Finalization	MM/DD/YYYY						

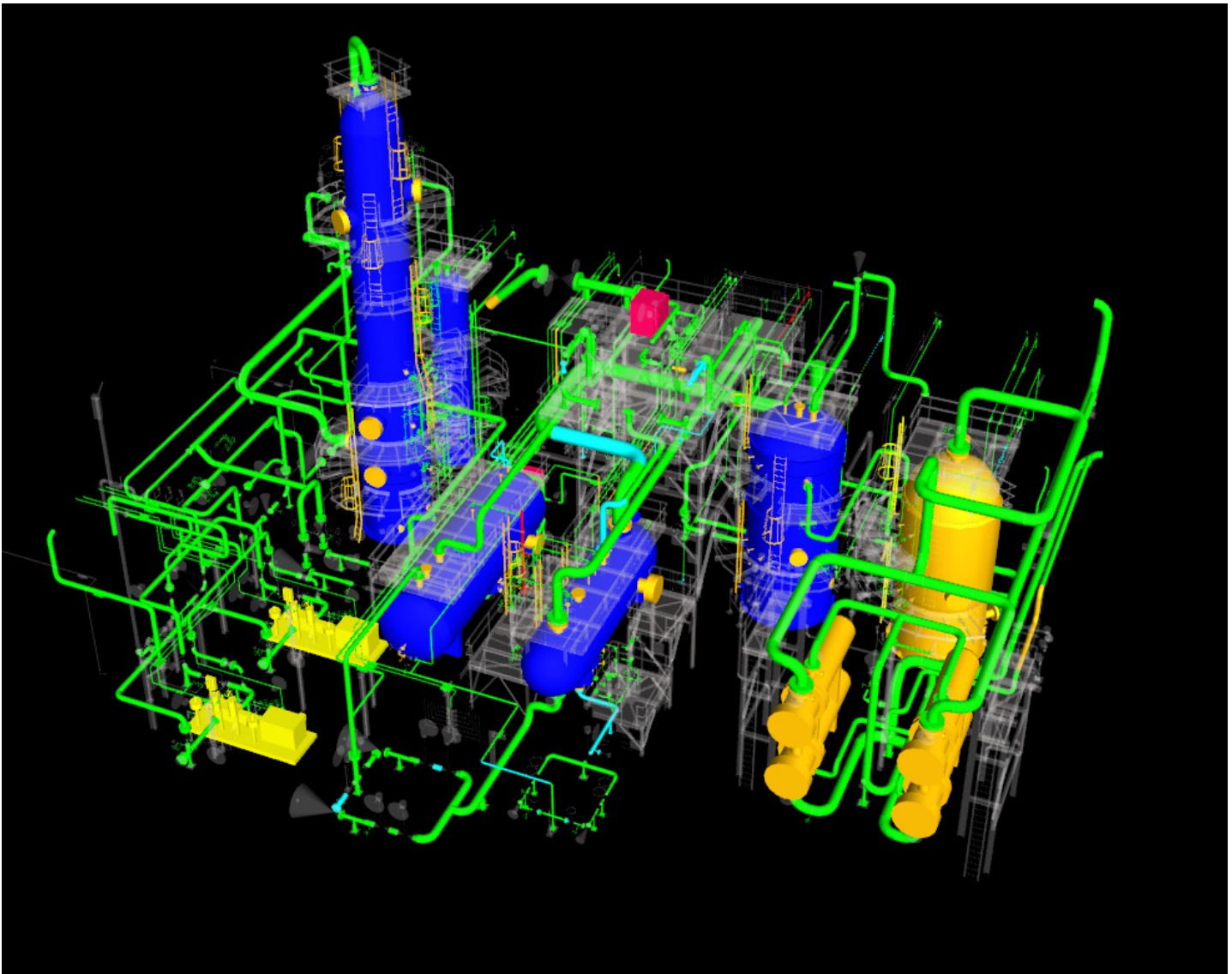



# ENGINEERING WORK PACKAGE

<b>Project Name:</b>									
<b>Project WBS No:</b>									
EWP		Plant		Area		Discipline		Sequence No	
E W P	-		-		-		-		
<b>Description:</b>									

Section No.	Section Description	# of Sheets
1.0	Scope of Work	
2.0	EWP Reference List	
3.0	Engineering Information	
4.0	Quality	
5.0	Vendor Support	
6.0	WorkFace Planning	
7.0	3D Model Shots of EWP	
8.0	Contact List	

## 1.0 SCOPE OF WORK

# ENGINEERING WORK PACKAGE

Project Name:

Project WBS No:

EWP	Plant	Area	Discipline	Sequence No
E W P -	-	-	-	-
Description:				

## 1.1 Summary Description of the Scope of Work

A summary description of the scope of this EWP is to be provided here. Reference additional EWPs.

## 1.2 Execution Strategy

Provide the strategic intent or Path of Construction for scopes to be executed in this EWP. Reference integration and interface requirements and Project Schedule.

## 1.3 Execution Milestones

Identify key milestone dates for scopes of work referenced based on the Level III Project Schedule.

## 1.4 Work Included

Include any scope items that are not contained in the defined EWPs, or where the referenced documents do not adequately convey the scope.

## 1.5 Work excluded

Identify work that is specifically not included that is not identified in the defined EWPs, or where the referenced documents do not adequately convey the limits of scope.

## 2.0 EWP REFERENCE LIST

### 2.1 EWP Reference List

Identify additional EWPs that must be referenced to understand scope and execution strategy.

# ENGINEERING WORK PACKAGE

Project Name:

Project WBS No:

EWP	Plant	Area	Discipline	Sequence No
E W P -	-	-	-	-
Description:				

## 3.0 ENGINEERING INFORMATION

### 3.1 Holds List

*Identify Hold and forecast release for documents listed but not released*

### 3.2 Additional Technical Information

*Identify any technical information that is not included in other documentation*

### 3.3 Technical document lists

*Identify and include the lists of technical documents included in this EWP*

## 4.0 QUALITY

### 4.1 Inspection and Test Plans

*All work defined in this EWP will be executed to requirements of Owner-approved Inspection and Test Plans (ITP). ITPs will be developed in compliance to Owner document XXX-XXX-000 Contractor Quality Requirements Specification Standard.*

### 4.2 Weld Procedures

*No welding process will be applied to the execution of scopes defined in this EWP without an approved Welding Procedure. Welding Procedures will satisfy welding requirements identified in EWPs listed in Section 2.0 EWP List.*

# ENGINEERING WORK PACKAGE

Project Name:

Project WBS No:

EWP	Plant	Area	Discipline	Sequence No
E W P -	-	-	-	-
Description:				

## 5.0 VENDOR SUPPORT

### 5.1 Equipment List Vendor Requiring Support

*Provide a list of applicable equipment that will require vendor assistance.*

### 5.2 Purchase Order Schedule

*Provide confirmation that a Contract or Purchase Order is in place.*

### 5.3 Vendor Contact Information

*Prepare a list of Vendor contact information, notification requirements and anticipated required at site dates.*

# ENGINEERING WORK PACKAGE

Project Name:

Project WBS No:

EWP	Plant	Area	Discipline	Sequence No
E W P -	-	-	-	-

Description:

## 6.0 WORKFACE PLANNING

### 6.1 Field Installation Work Package List and Schedule

*A detailed breakdown of the planned number IWPs associated with the EWP is to be provided by the Contractor along with the release plan.*

The Contractor Shall follow the implementation practices as described but CII and COAA.

(Insert Links to Web information for COAA, CII, and the 272IR)

# ENGINEERING WORK PACKAGE

Project Name:

Project WBS No:

EWP	Plant	Area	Discipline	Sequence No
E W P -	-	-	-	-
Description:				

## 7.0 3D Model Shots Of EWP

### 7.0 Model Shots

*Include here several 3D model shots of the EWP*

## 8.0 Contact List

### 8.0 Contact List

*Provide a comprehensive list of Contact Information for:*

- *Project Personnel*
- *Engineering Personnel*
- *Materials Management*
- *Vendors*
- *Document Owners*

<b>Project name</b>  <b>Project Logo</b>	<b>WP#</b>	<b>Unit</b>	<b>Cost Area</b>	<b>Const. Area</b>	<b>System Code</b>	<b>Disc.</b>	<b>Seq.</b>		
	XX	XX	XXX	XX	XX	XX	XX		
	Area: xxxxxx xxxx			Discipline: xxxxxx			Preparer: xxxxxx xxxxxx		
	WP Description: xxxxxxxxxxxxxxxxxxxxxxxxxxxxxxxx								

**Project Name**  
**48 HOUR NOTICE OF SCAFFOLD REQUEST**  
 Please Print all information

Tag Number:		Date:
Date Requested:	Date Needed:	Craft Requested:
Time Requested:	Foreman:	Radio Channel:
Type of Scaffold Needed: (from Grade, Hanging, Rolling Scaffold, etc.)		
Size of Scaffold Needed:		
Location of Scaffold (Be Specific):		
How long will scaffold be needed:		
<b>MODIFICATIONS</b>		
Tag Number:	Date Requested:	Date Needed:
Craft Requested:	Foreman:	Radio Channel:
Describe Modification Required:		
<b>TEAR DOWN</b>		
Date Requested:	Craft Requesting:	Tag Number:
Foreman:	Priority Tear Down? YES or NO	Superintendent:
Quality Control:	Civil:	Insulator:
Painter:	Electrician:	Instrumentation:
Millwright:	Pipe:	Start Up:

Leave for binding

## IWP ELECTRICAL

PROJECT INFORMATION				
Project Number	IWP Number & Revision Number	All Related CWP & Revision Number	Area/System/Subsystem/Discipline	Work Performed by
1000	IWP 8120-051	CWP 8120-01	Area 8120 - Electrical	

AUTHORSHIP AND APPROVALS		
<b>Prepared by</b>		01 NOV 07
<b>Revised By</b>		01 NOV 07
<b>Issued by</b>		01 NOV 07
<b>Released by</b>		
<b>Assigned by</b>		
<b>Reason to Recall</b>		
<b>Completed by</b>		



## Scope

Install 300 meters of 60cm, 200 meters of 30cm and 300 meters of 10 cm cable tray with down comers, all complete with structural steel supports within Compressor Building 8120-BG-001. See Drawing #8120-65N-042 for lay out, elevation and details.

## Deliverable

800 meters of cable tray ready for wire pull commencing 15 May 2006. Activities

## Activities

- The welding crew shall install, 25 type CTS 60T, 20 type CTS 60A, 30 type CTS 30T, 12 type CTS 60, 6 type CTS 30, 100 type CTS 10 cable tray supports welded to the building structural steel. 80 hours each for structural steel welder and helper/fitter.
- The Electrical crew shall bolt the cable tray to the supports 60 cm, 30 cm, 10 cm cable tray with bends and tees as indicated on drawing #8120-65N-042 and standards drawing #8000-65-002. 80 hours for a four-man crew (an Electrician with 2 – apprentice and one helper).

## Resources

## Equipment

- Portable mobile welding machine and man lift for welding crew.
- 2 man lifts and steel cutting mitre saw

## Tools

General hand tools for Welder and Electrician.

## Materials

- 25 – type CTS 60T cable tray support
- 20 – type CTS 60A cable tray support
- 30 – type CTS 30T cable tray support
- 12 – type CTS 60 cable tray support
- 6 – type CTS 30 cable tray support
- 100 – type CTS 10 cable tray support
- 300 meters Standard 60cm cable tray
- 200 meters Standard 30cm cable tray.
- 300 meters Light Weight 10cm cable tray
- 2 – cable tray 90 elbow type 2 60 cm
- 2 – cable tray 90 elbow type 3 60 cm
- 3 - cable tray tee type 4 60 cm
- 5 - cable tray end caps type 2 60 cm
- 4 – cable tray 90 elbow type 2 30 cm
- 4 – cable tray 90 elbow type 3 30 cm
- 2 – cable tray tee type 4 30 cm
- 45 - cable tray coupling 60 cm type L2 with nuts and bolts
- 30 – cable tray coupling 30 cm type L2 with nuts and bolts
- 50 – cable tray coupling 10 cm type 1 with nuts and bolts
- 100 - cable tray bonding clamps complete type 5

## Labour

- Structural Steel Welder.
- Fitter/Helper
- Electrician
- 2 - Apprentice
- 1 – Helper

## Work Instructions

Other trades shall be working in the Compressor building during the installation of the Cable Tray and supports. As the welder and electrical crews will be working most of the time from a

man lift, care must be taken of falling materials and tools on fellow workers below. Areas should be ribboned off to restrict access.

## Safety Equipment

- Training required for use of man-lift for complete crew.
- Safety Harness training for all members of the crew.

## Drawings

- Building general arrangement #8120-BG-001
- Cable Tray routing #8120-65N-042
- Cable tray installation standards #8000-65-002

## Vendor Information

- XYZ Speciality company supplier of CTFS wonder fastener.
- Vendor drawing number: 100-elec-8120-4

## Special Conditions

Special cable tray fastening system (CTFS) required due to operations request.

## Quality Control

Ensure that team installing the CTFS has vendor supplied installation details.

## Interdependencies

The building structural steel and large bore pipe shall be installed before welder's mobilized. Welder to start east wall, north end working south around the building, Electrical trades to

start approximately three days after welder crew has started and completed the supports for the east wall as a minimum.

## **Risk Planning**

## **Reverse Punch List (Error Proofing)**

## **Lessons Learned**

The CTFS system requested by operations was easy to install and saved approximately 20 minutes per connection.

## IWP PIPING

PROJECT INFORMATION				
Project Number	IWP Number & Revision Number	All Related CWP & Revision Number	Area/System/Subsystem/Discipline	Work Performed by
2111	IWP 2111-121	CWP 2111-01	Area 2111 - Piping	

AUTHORSHIP AND APPROVALS		
<b>Prepared by</b>		01 NOV 07
<b>Revised By</b>		01 NOV 07
<b>Issued by</b>		01 NOV 07
<b>Released by</b>		
<b>Assigned by</b>		
<b>Reason to Recall</b>		
<b>Completed by</b>		

## Scope

Install, fit and weld 24" carbon steel large bore piping from pump P-5304 discharge flange to Vessel C2112 inlet flange. The tower is 60' tall and the inlet flange is located at the top of the tower with a service platform 2' below. The pump is located 50' SE to the tower, the piping is elevated to 12 feet above grade and running west and north to south side of the tower and up to the nozzle.

The piping is fabricated into 3 spools A, B & C and requires 2 field welds after installation. The piping has two free standing pipe supports at grade and 2 located on the side of the tower.

Estimate spool length spool "A" is 50' long, spool "B" is 30' and spool "C" is 40' plus.

See DWG# \_\_\_\_\_ & ISO \_\_\_\_\_.

## Deliverable

- Pipe supports materials, pipe spools, gaskets and hardware material for work commencing on Oct 10-12.
- -Required an 80-ton crane for spool erection and a 30 ton for tailing and pipe support installation.
- -Scaffold must be in place prior to work commencing.

## Activities

### Sequence of spools installation from tower to pump

- Surveyors to verify centerline and elevation on pipe support foundations.
- Erect scaffolds at pipe support and field joints for access. Leave temporary access for spool installation.
- Piping crew to verify piping materials, gasket and hardware, spool dimensions, check for shipping damage, and prepare for installation.
- Transport material and spools from lay down yard to installation site.
- Install pipe supports, once installed surveyor to verify elevation

- Setup 80t crane east of tower and lay spool north of crane running east/west with tower connection on west side. And setup tailing 30t crane on tail end of spool.
- Prepare rigging material, verify sling sizes and length, check for damage.
- Lift and install spool "A" from tower inlet flange down using an 80 ton for the main lift and 30t for tailing. Secure spool with two tower supports.
- Install spool "B" on pipe support and temporary fit and secure to spool "A".
- Install spool "C" temporary bolt to pump discharge flange and secure to pipe support.
- Review attached welding procedure and verify welding rods.
- Align pipe flange to pump discharge, fit and weld two joints with QC inspection and approval of welding.
- NDE joints.
- Bolt up crew to check bolt tension on flanges and pipe support.
- Dismantle scaffolds.
- Daily progress report.

Next step is hydro piping and EHT and insulation

## Resources

## Equipment

- 80T mobile crane for spool installation and a 30t for tailing and install pipe supports.
- One Rectifier welding machine; rod oven.
- One set of Surveyor equipment.

## Tools

- Rigging wire slings and shackles,
- Oxy/Acct. cutting outfit, welding lead; hand grinders; rasp file; 1 7/8" combination wrenches, 1 7/8" torque wrench and pipe fitter hand tools.

## Materials

- Pipe support materials and 3 spools at lay down yard.
- Hardware and gaskets are bagged and tagged at warehouse.
- Welding rods are in tool crib in welding rod's oven.
- Scaffolding material.

## Labour

- 1 – Scaffold F/M 3 Scaffolders and 1 labour.
- 1 – Piping foreman; 3 p/f riggers, 1 fitter, 1B-pressure welders and 1 apprentice.

## Work Instructions

- All crane operators must have project certification. Welders must be tested on site.
- Setup red flagging and clear rigging area; complete SPA before work proceeds.
- Setup welding hoarding or screens and sparks containment and covers up equipment below.
- Maintain a fire watch when welding and cutting.
- Coordinate with other craft and Forman working around the same area.

## Safety Equipment

- Barricade tape; fire extinguishers; safety harness; respirators and smoke removal.

## Drawings

- Piping Isometric
  - 53-LP-2110-CS-111 sheet 1 Rev 3
  - 53-LP-2110-CS-111 sheet 2 Rev 3
- Spool Drawing
  - 53-LP -0211-CS- A
  - 53-LP -0211-CS- B



- 53-LP -0211-CS- C

## Vendor Information

Piping fabricator to provide piping cut sheets & inform of any RFIs, changes or materials are outstanding.

## Special Conditions

We will be working at heights for a lot of this IWP so take time in the morning and after lunch to reinforce 'working at heights' safety standard. Exercise and stretch in the morning before climbing the tower. Apprentice must be teamed with a journeyman.

## Quality Control

- All bolts are to be torque to project spec 2111-ST-S2 rev 1. Spec is attached.
- Welding inspector to check on welder periodically and verify correct welding rods.
- Notify Willy Engineer for a spot check on bolt tensioning.

## Interdependencies

This work package is dependent on the availability an 80T cranes which are currently being used by Ironworker installing structural steel. One week prior to start of work confirm the availability of the crane.

## Risk Planning

- Do a hazard analysis before rigging spool to connect to top of tower.
- Conduct pre lift meeting with crew directly prior to lift occurring.

## Reverse Punch List (Error Proofing)

- We have recently experienced some quality issues. Wrong gasket material was delivered to site for installation at pump's discharge flange.
- Have experienced fitter verify the gasket material against drawing's material list before installation and inform Forman Dale if any discrepancies.

## Lessons Learned

Warehouse personnel must verify all material before delivery to site for installation.

## IWP STRUCTURAL STEEL

PROJECT INFORMATION				
Project Number	IWP Number & Revision Number	All Related CWP & Revision Number	Area/System/Subsystem/Discipline	Work Performed by
1000	IWP 8120-121	CWP 8120-2	Area 8120 - Structural	

AUTHORSHIP AND APPROVALS		
<b>Prepared by</b>		01 NOV 07
<b>Revised By</b>		01 NOV 07
<b>Issued by</b>		01 NOV 07
<b>Released by</b>		
<b>Assigned by</b>		
<b>Reason to Recall</b>		
<b>Completed by</b>		

## Scope

Install bridge crane steel in the Compressor Shelter and access stairway from the Compressor Shelter to the east/west pipe rack. The Compressor Shelter is located in the NE corner of Area 8120. The bridge crane steel runs the entire length of the Compressor Shelter along the north and south walls at approximately elevation 85'. The stairway is at the west end of the Compressor Shelter and runs plant north to the top of the pipe rack. The stairway starts at elevation 85' and goes to elevation 102' at the top of the pipe rack. The platform at elevation 85' is approximately 31' feet above the existing grade with clear access from the west side of the Compressor Shelter.

## Deliverable

- Completed installation of the bridge crane steel in preparation of the bridge crane arrival on 15 Oct 12.
- Complete the stairway installation to allow the ongoing pipe and electrical installation at elevation 102' of the east/west pipe rack.

## Activities

This work represents two (2) weeks of work for the crew.

The structural steel crew will shake out the steel for the described work and stage the materials for delivery to the west end of the Compressor Shelter. This will take two days. The erection team will commence installing approximately 15 tons of bridge crane steel starting at the east end north side then moving to the south side. This will be time consuming work due to the congestion and amount of work that will be performed from manbaskets.

The bolt up crew will start the preassembly of the stair stringers and treads along with the landing platforms at ground level on the west end of the Compressor Shelter. All handrails and grating will be installed at grade.

The bolt up crew will move to the north side bridge crane steel once the erection crew moves to the south side. We will have to watch the movement of the manlifts so as not to interfere with the two work activities on either side of the shelter.

Once erection is complete in the Compressor Shelter the erection team will move on to the installation of the stairway and landing platforms.

A reminder that the sheeting contractor will be working on the outside of the north and south walls while we are doing our erection on the inside.

## Resources

### Equipment (See Construction Equipment Schedule for details)

- 3990T Crane
- 65T Mobile
- 2 – 80 foot manlift
- 3 – flatbed trailers(part time)
- air compressor
- 2 – welding machines
- 4 – 50 retractable connectors
- 4 – 50 retractable connectors

## Tools

- 3 – impact guns
- 1 – mag drill
- 2 – 20' extension ladders
- 200' welding lead
- hammer wrenches – 1 ¼ " and 1 5/8"
- selection of wire slings and shackles

## Materials

- All steel is available in the steel laydown yard reference grid 12B.
- Bolts and nuts; 3X3 shims; grating clips; bridge crane rail hold down brackets; all these items are at the warehouse bagged and tagged reference location row 2 shelf B3.

- 1/2" inch wire rope and Crosby clips

## Labour

- 1 – working foreman;
- 4 – journeyman IW;
- 2 – apprentice;
- 2 – helpers;
- 2 - operators

## Work Instructions

- All manlift operators must have project certification.
- Several pieces of equipment are installed at the east end of the building and must be protected from weld splatter and falling tools. Use scaffolding frames with 5/8 inch plywood and fire blanket to cover the equipment.
- Red flag the selected areas of overhead work.
- Work closely with Jim Siding, foreman for GOOD Enclosures INC, working on the outside of the north wall of the Shelter.

## Safety Equipment

Barricade tape; fire extinguishers; safety harness; and lanyards.

## Drawings

- Compressor Shelter - Isometric View Dwg 8120-stru-112 rev 3;
- Framing Sheets Dwg 8120-stru-113 rev 2 Sheets 1 to 5
- Elevations Dwg 8120-stru-110 rev 2 Sheets 1 to 4
- Stair Sections Dwg 8120-stru-114 rev 1
- Sections & Details Dwg 8120-stru-115 rev 2 Sheets 1 to 3

## Vendor Information

Big Steel Fabricators (BFS) have included all erection drawings with appropriate piece Sepks. They have supplied nuts and bolts with a 10% bump. A set of erection drawings are attached and the nuts and bolts are bagged and tagged in Bin 72/ Row 6 at the main warehouse.

## Special Conditions

- We will be working at heights for a lot of this IWP so take time in the morning and after lunch to reinforce 'working at heights' safety standard.
- Permit required when access to Compressor Shelter is blocked during setting of crane rails.
- The 2 – apprentice have just recently joined the project so they must be teamed with a journeyman while working at heights.

## Quality Control

- All bolts are to be tortured per the project spec 8120-stru-S2 rev 1. Specs including weld procedures are attached.
- Notify Wil Engineer for a spot check on bolt tensioning. CYY Crane Company will inspect all crane rail supports prior to rail installation.

## Interdependencies

This work package is dependent on the availability of 2 – 80' manlifts which are currently being used by electricians running cable tray. One week prior to start of work confirm the availability on the equipment and order short term rental if electrical work is not complete.

## Risk Planning

At this time, there is no known risk that would prevent the work package from proceeding.

## Reverse Punch List (Error Proofing)

- We have recently experienced some quality issues related to bolt tensioning. After each bolt is tensioned the nut will be Sepked with a yellow Sepk to indicate the work is complete.
- We have also had some issues with the BFS's piece Sepks not matching the deliver inventory. Our experience has shown that the piece Sepk on the steel is correct and matches the erection drawing. If this occurs notify Jim Bob Receiver at the warehouse.

## Lessons Learned

To be added at completion of the job. Team meeting to be held with Ron Planner to capture the LL.

## List of Attachments

1. Three Week Area Schedule
2. Construction Equipment Schedule
3. Material Report
4. Weld Procedures
5. Specs
6. Access/Egress Permit
7. Quantity and Unit Rate Report